

10" Table Saw

(Model TS220LS)



PART NO. 905579 - 03-24-04
Copyright © 2004 Delta Machinery

 **DELTA**[®] *ShopMaster*[™]

To learn more about DELTA MACHINERY
visit our website at: www.deltamachinery.com.

For Parts, Service, Warranty or other Assistance,

please call **1-800-223-7278** (In Canada call **1-800-463-3582**).

ESPAÑOL: PÁGINA 29

SAFETY GUIDELINES - DEFINITIONS

This manual contains information that is important for you to know and understand. This information relates to protecting YOUR SAFETY and PREVENTING EQUIPMENT PROBLEMS. To help you recognize this information, we use the symbols to the right. Please read the manual and pay attention to these sections.

▲ DANGER Indicates an imminently hazardous situation which, if not avoided, will result in death or serious injury.

▲ WARNING Indicates a potentially hazardous situation which, if not avoided, could result in death or serious injury.

▲ CAUTION Indicates a potentially hazardous situation which, if not avoided, may result in minor or moderate injury.

CAUTION Used without the safety alert symbol indicates potentially hazardous situation which, if not avoided, may result in property damage.

▲ WARNING SOME DUST CREATED BY POWER SANDING, SAWING, GRINDING, DRILLING, AND OTHER CONSTRUCTION ACTIVITIES contains chemicals known to cause cancer, birth defects or other reproductive harm. Some examples of these chemicals are:

- lead from lead-based paints,
- crystalline silica from bricks and cement and other masonry products, and
- arsenic and chromium from chemically-treated lumber.

Your risk from these exposures varies, depending on how often you do this type of work. To reduce your exposure to these chemicals: work in a well ventilated area, and work with approved safety equipment, always wear **MSHA/NIOSH** approved, properly fitting face mask or respirator when using such tools.

GENERAL SAFETY RULES



▲ WARNING READ AND UNDERSTAND ALL WARNINGS AND OPERATING INSTRUCTIONS BEFORE USING THIS EQUIPMENT. Failure to follow all instructions listed below, may result in electric shock, fire, and/or serious personal injury or property damage.

IMPORTANT SAFETY INSTRUCTIONS

Woodworking can be dangerous if safe and proper operating procedures are not followed. As with all machinery, there are certain hazards involved with the operation of the product. Using the machine with respect and caution will considerably lessen the possibility of personal injury. However, if normal safety precautions are overlooked or ignored, personal injury to the operator may result. Safety equipment such as guards, push sticks, hold-downs, featherboards, goggles, dust masks and hearing protection can reduce your potential for injury. But even the best guard won't make up for poor judgment, carelessness or inattention. Always use common sense and exercise caution in the workshop. If a procedure feels dangerous, don't try it. Figure out an alternative procedure that feels safer. **REMEMBER:** Your personal safety is your responsibility. For additional information please visit our website www.deltamachinery.com.

▲ WARNING This machine was designed for certain applications only. Delta Machinery strongly recommends that this machine not be modified and/or used for any application other than that for which it was designed. If you have any questions relative to a particular application, **DO NOT** use the machine until you have first contacted Delta to determine if it can or should be performed on the product.

Technical Service Manager
Delta Machinery
4825 Highway 45 North
Jackson, TN 38305
(IN CANADA: 505 SOUTHGATE DRIVE, GUELPH, ONTARIO N1H 6M7)

GENERAL SAFETY RULES

▲ WARNING FAILURE TO FOLLOW THESE RULES MAY RESULT IN SERIOUS INJURY.

- 1. FOR YOUR OWN SAFETY, READ THE INSTRUCTION MANUAL BEFORE OPERATING THE MACHINE.** Learning the machine's application, limitations, and specific hazards will greatly minimize the possibility of accidents and injury.
- 2. WEAR EYE PROTECTION. ALWAYS USE SAFETY GLASSES.** Also use face or dust mask if cutting operation is dusty. Everyday eyeglasses are NOT safety glasses. **USE CERTIFIED SAFETY EQUIPMENT.** Eye protection equipment should comply with ANSI Z87.1 standards, hearing equipment should comply with ANSI S3.19 standards, and dust mask protection should comply with MSHA/NIOSH certified respirator standards. Splinters, air-borne debris, and dust can cause irritation, injury, and/or illness.
- 3. WEAR PROPER APPAREL.** Do not wear loose clothing, gloves, neckties, rings, bracelets, or other jewelry which may get caught in moving parts. Nonslip footwear is recommended. Wear protective hair covering to contain long hair.
- 4. DO NOT USE THE MACHINE IN A DANGEROUS ENVIRONMENT.** The use of power tools in damp or wet locations or in rain can cause shock or electrocution. Keep your work area well-lit to prevent tripping or placing arms, hands, and fingers in danger.
- 5. MAINTAIN ALL TOOLS AND MACHINES IN PEAK CONDITION.** Keep tools sharp and clean for best and safest performance. Follow instructions for lubricating and changing accessories. Poorly maintained tools and machines can further damage the tool or machine and/or cause injury.
- 6. CHECK FOR DAMAGED PARTS.** Before using the machine, check for any damaged parts. Check for alignment of moving parts, binding of moving parts, breakage of parts, and any other conditions that may affect its operation. A guard or any other part that is damaged **should be properly repaired or replaced.** Damaged parts can cause further damage to the machine and/or injury.
- 7. KEEP THE WORK AREA CLEAN.** Cluttered areas and benches invite accidents.
- 8. KEEP CHILDREN AND VISITORS AWAY.** Your shop is a potentially dangerous environment. Children and visitors can be injured.
- 9. REDUCE THE RISK OF UNINTENTIONAL STARTING.** Make sure that the switch is in the "OFF" position before plugging in the power cord. In the event of a power failure, move the switch to the "OFF" position. An accidental start-up can cause injury.
- 10. USE THE GUARDS.** Check to see that all guards are in place, secured, and working correctly to prevent injury.
- 11. REMOVE ADJUSTING KEYS AND WRENCHES BEFORE STARTING THE MACHINE.** Tools, scrap pieces, and other debris can be thrown at high speed, causing injury.
- 12. USE THE RIGHT MACHINE.** Don't force a machine or an attachment to do a job for which it was not designed. Damage to the machine and/or injury may result.
- 13. USE RECOMMENDED ACCESSORIES.** The use of accessories and attachments not recommended by Delta may cause damage to the machine or injury to the user.
- 14. USE THE PROPER EXTENSION CORD.** Make sure your extension cord is in good condition. When using an extension cord, be sure to use one heavy enough to carry the current your product will draw. An undersized cord will cause a drop in line voltage, resulting in loss of power and overheating. See the Extension Cord Chart for the correct size depending on the cord length and nameplate ampere rating. If in doubt, use the next heavier gauge. The smaller the gauge number, the heavier the cord.
- 15. SECURE THE WORKPIECE.** Use clamps or a vise to hold the workpiece when practical. Loss of control of a workpiece can cause injury.
- 16. FEED THE WORKPIECE AGAINST THE DIRECTION OF THE ROTATION OF THE BLADE, CUTTER, OR ABRASIVE SURFACE.** Feeding it from the other direction will cause the workpiece to be thrown out at high speed.
- 17. DON'T FORCE THE WORKPIECE ON THE MACHINE.** Damage to the machine and/or injury may result.
- 18. DON'T OVERREACH.** Loss of balance can make you fall into a working machine, causing injury.
- 19. NEVER STAND ON THE MACHINE.** Injury could occur if the tool tips, or if you accidentally contact the cutting tool.
- 20. NEVER LEAVE THE MACHINE RUNNING UNATTENDED. TURN THE POWER OFF.** Don't leave the machine until it comes to a complete stop. A child or visitor could be injured.
- 21. TURN THE MACHINE "OFF", AND DISCONNECT THE MACHINE FROM THE POWER SOURCE** before installing or removing accessories, before adjusting or changing set-ups, or when making repairs. An accidental start-up can cause injury.
- 22. MAKE YOUR WORKSHOP CHILDPROOF WITH PADLOCKS, MASTER SWITCHES, OR BY REMOVING STARTER KEYS.** The accidental start-up of a machine by a child or visitor could cause injury.
- 23. STAY ALERT, WATCH WHAT YOU ARE DOING, AND USE COMMON SENSE. DO NOT USE THE MACHINE WHEN YOU ARE TIRED OR UNDER THE INFLUENCE OF DRUGS, ALCOHOL, OR MEDICATION.** A moment of inattention while operating power tools may result in injury.
- 24. TAKE PRECAUTIONS AGAINST DUST INHALATION.** The dust generated by certain woods and wood products can be injurious to your health. Always operate machinery in well-ventilated areas, and provide for proper dust removal. Use wood dust collection systems whenever possible.

ADDITIONAL SAFETY RULES FOR TABLE SAWS

⚠ WARNING FAILURE TO FOLLOW THESE RULES MAY RESULT IN SERIOUS INJURY.

- DO NOT OPERATE THIS MACHINE** until it is **assembled** and **installed** according to the instructions.
- OBTAIN ADVICE FROM YOUR SUPERVISOR, instructor, or another qualified person** if you are not familiar with the operation of this machine.
- FOLLOW ALL WIRING CODES** and recommended electrical connections.
- USE THE GUARDS WHENEVER POSSIBLE.** Check to see that they are in place, secured, and working correctly.
- KICKBACK IS THE NATURAL TENDENCY OF THE WORKPIECE TO BE THROWN BACK AT THE OPERATOR** when the workpiece initially contacts the blade or if the workpiece pinches the blade. Kickback is dangerous and can result in serious injury.
AVOID KICKBACK by:
 - keeping blade sharp and free of rust and pitch.
 - keeping rip fence parallel to the saw blade.
 - using saw blade guard and spreader for every possible operation, including all through sawing.
 - pushing the workpiece past the saw blade prior to release.
 - never ripping a workpiece that is twisted or warped, or does not have a straight edge to guide along the fence.
 - using featherboards when the anti-kickback device cannot be used.
 - never sawing a large workpiece that cannot be controlled.
 - never using the fence as a guide when crosscutting.
 - never sawing a workpiece with loose knots or other flaws.
- ALWAYS USE GUARDS, SPLITTER, AND ANTI-KICKBACK FINGERS** whenever possible.
- REMOVE CUT-OFF PIECES AND SCRAPS** from the table before starting the saw. The vibration of the machine may cause them to move into the saw blade and be thrown out. After cutting, turn the machine off. After the blade has **come to a complete stop, remove all debris.**
- NEVER START THE MACHINE** with the workpiece against the blade.
- NEVER** run the workpiece between the fence and a moulding cutterhead.
- CUTTING THE WORKPIECE WITHOUT THE USE OF A FENCE OR MITER GAUGE IS KNOWN AS “FREEHAND” CUTTING. NEVER** perform “free-hand” operations. Use either the fence or miter gauge to position and guide the workpiece.
- HOLD THE WORKPIECE FIRMLY** against the miter gauge or fence.
- CUTTING COMPLETELY THROUGH THE WORKPIECE IS KNOWN AS “THROUGH-SAWING”.** Ripping and cross-cutting are through-sawing operations. Cutting with the grain (or down the length of the workpiece) is ripping. Cutting across the grain (or across the workpiece) is cross-cutting. Use a fence or fence system for ripping. **DO NOT** use a fence or fence system for cross-cutting. Instead, use a miter gauge. **USE PUSH STICK(S)** for ripping a narrow workpiece.
- AVOID AWKWARD OPERATIONS AND HAND POSITIONS** where a sudden slip could cause a hand to move into the blade.
- KEEP ARMS, HANDS, AND FINGERS** away from the blade.
- NEVER** have any part of your body in line with the path of the saw blade.
- NEVER REACH AROUND** or over the saw blade.
- NEVER** attempt to free a stalled saw blade without first turning the machine “OFF”.
- PROPERLY SUPPORT LONG OR WIDE** workpieces.
- NEVER PERFORM LAYOUT,** assembly or set-up work on the table/work area when the machine is running.
- TURN THE MACHINE “OFF” AND DISCONNECT THE MACHINE** from the power source before installing or removing accessories, before adjusting or changing set-ups, or when making repairs.
- TURN THE MACHINE “OFF”,** disconnect the machine from the power source, and clean the table/work area before leaving the machine. **LOCK THE SWITCH IN THE “OFF” POSITION** to prevent unauthorized use.
- ADDITIONAL INFORMATION** regarding the safe and proper operation of power tools (i.e. a safety video) is available from the Power Tool Institute, 1300 Sumner Avenue, Cleveland, OH 44115-2851 (www.powertoolinstitute.com). Information is also available from the National Safety Council, 1121 Spring Lake Drive, Itasca, IL 60143-3201. Please refer to the American National Standards Institute ANSI O1.1 Safety Requirements for Woodworking Machines and the U.S. Department of Labor OSHA 1910.213 Regulations.

**SAVE THESE INSTRUCTIONS.
Refer to them often
and use them to instruct others.**

POWER CONNECTIONS

A separate electrical circuit should be used for your machines. This circuit should not be less than #12 wire and should be protected with a 20 Amp time lag fuse. If an extension cord is used, use only 3-wire extension cords which have 3-prong grounding type plugs and matching receptacle which will accept the machine's plug. Before connecting the machine to the power line, make sure the switch is in the "OFF" position and be sure that the electric current is of the same characteristics as indicated on the machine. All line connections should make good contact. Running on low voltage will damage the machine.

⚠ DANGER DO NOT EXPOSE THE MACHINE TO RAIN OR OPERATE THE MACHINE IN DAMP LOCATIONS.

MOTOR SPECIFICATIONS

Your machine is wired for 120 volt, 60 HZ alternating current. Before connecting the machine to the power source, make sure the switch is in the "OFF" position.

GROUNDING INSTRUCTIONS

⚠ DANGER THIS MACHINE MUST BE GROUNDED WHILE IN USE TO PROTECT THE OPERATOR FROM ELECTRIC SHOCK.

1. All grounded, cord-connected machines:

In the event of a malfunction or breakdown, grounding provides a path of least resistance for electric current to reduce the risk of electric shock. This machine is equipped with an electric cord having an equipment-grounding conductor and a grounding plug. The plug must be plugged into a matching outlet that is properly installed and grounded in accordance with all local codes and ordinances.

Do not modify the plug provided - if it will not fit the outlet, have the proper outlet installed by a qualified electrician.

Improper connection of the equipment-grounding conductor can result in risk of electric shock. The conductor with insulation having an outer surface that is green with or without yellow stripes is the equipment-grounding conductor. If repair or replacement of the electric cord or plug is necessary, do not connect the equipment-grounding conductor to a live terminal.

Check with a qualified electrician or service personnel if the grounding instructions are not completely understood, or if in doubt as to whether the machine is properly grounded.

Use only 3-wire extension cords that have 3-prong grounding type plugs and matching 3-conductor receptacles that accept the machine's plug, as shown in Fig. A.

Repair or replace damaged or worn cord immediately.

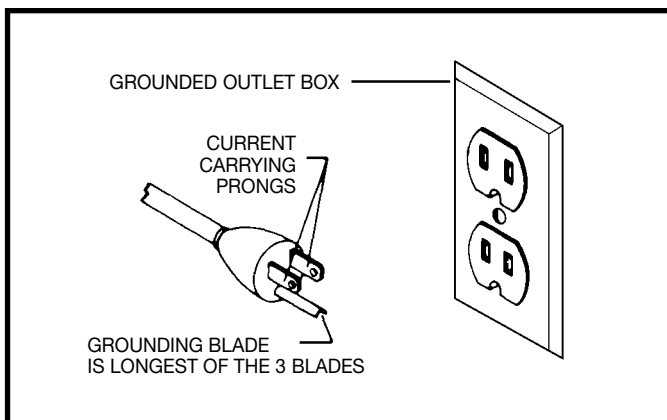

Fig. A

2. Grounded, cord-connected machines intended for use on a supply circuit having a nominal rating less than 150 volts:

If the machine is intended for use on a circuit that has an outlet that looks like the one illustrated in Fig. A, the machine will have a grounding plug that looks like the plug illustrated in Fig. A. A temporary adapter, which looks like the adapter illustrated in Fig. B, may be used to connect this plug to a matching 2-conductor receptacle as shown in Fig. B if a properly grounded outlet is not available. The temporary adapter should be used only until a properly grounded outlet can be installed by a qualified electrician. The green-colored rigid ear, lug, and the like, extending from the adapter must be connected to a permanent ground such as a properly grounded outlet box. Whenever the adapter is used, it must be held in place with a metal screw.

NOTE: In Canada, the use of a temporary adapter is not permitted by the Canadian Electric Code.

3. 240 VOLT SINGLE PHASE OPERATION:

The motor supplied with your saw is a dual voltage, 120/240 volt motor. If it is desired to operate your saw at 240 volts, single phase, it is necessary to reconnect the motor leads in the motor junction box by following the instructions given on the motor nameplate.

⚠ WARNING MAKE SURE MOTOR IS DISCONNECTED FROM POWER SOURCE BEFORE RECONNECTING MOTOR LEADS.

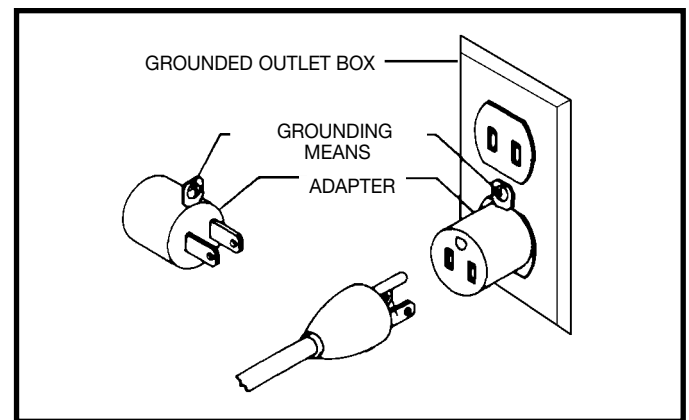

Fig. B

It is also necessary to replace the 120 volt plug, supplied with the motor, with a UL/CSA Listed plug suitable for 240 volts and the rated current of the saw as illustrated in Fig. C. Contact your local Authorized Delta Service Center or qualified electrician for proper procedures to install the plug. The saw must comply with all local and national electrical codes after the 240 volt plug is installed.

The saw with a 240 volt plug should only be connected to an outlet having the same configuration as the plug illustrated in Fig. C. No adapter is available or should be used with the 240 Volt plug.

DANGER IN ALL CASES, MAKE CERTAIN THE RECEPTACLE IN QUESTION IS PROPERLY GROUNDED. IF YOU ARE NOT SURE HAVE A QUALIFIED ELECTRICIAN CHECK THE RECEPTACLE.

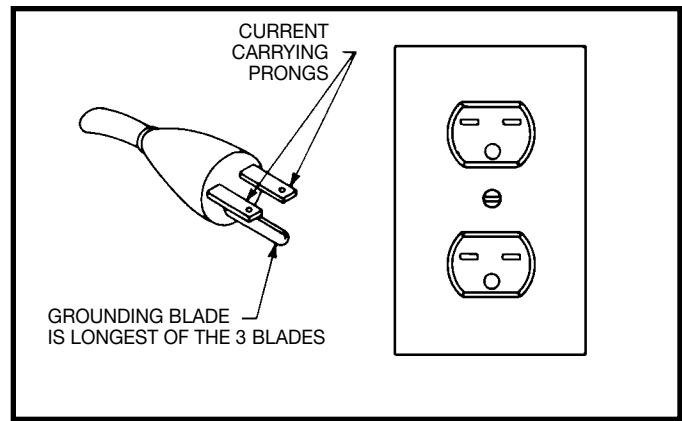

Fig. C

EXTENSION CORDS

CAUTION Use proper extension cords. Make sure your extension cord is in good condition and is a 3-wire extension cord which has a 3-prong grounding type plug and matching receptacle which will accept the machine's plug. When using an extension cord, be sure to use one heavy enough to carry the current of the machine. An undersized cord will cause a drop in line voltage, resulting in loss of power and overheating. Fig. D-1 or D-2, shows the correct gauge to use depending on the cord length. If in doubt, use the next heavier gauge. The smaller the gauge number, the heavier the cord.

MINIMUM GAUGE EXTENSION CORD			
RECOMMENDED SIZES FOR USE WITH STATIONARY ELECTRIC MACHINES			
Ampere Rating	Volts	Total Length of Cord in Feet	Gauge of Extension Cord
0-6	120	up to 25	18 AWG
0-6	120	25-50	16 AWG
0-6	120	50-100	16 AWG
0-6	120	100-150	14 AWG
6-10	120	up to 25	18 AWG
6-10	120	25-50	16 AWG
6-10	120	50-100	14 AWG
6-10	120	100-150	12 AWG
10-12	120	up to 25	16 AWG
10-12	120	25-50	16 AWG
10-12	120	50-100	14 AWG
10-12	120	100-150	12 AWG
12-16	120	up to 25	14 AWG
12-16	120	25-50	12 AWG
12-16	120	GREATER THAN 50 FEET NOT RECOMMENDED	

Fig. D-1

MINIMUM GAUGE EXTENSION CORD			
RECOMMENDED SIZES FOR USE WITH STATIONARY ELECTRIC MACHINES			
Ampere Rating	Volts	Total Length of Cord in Feet	Gauge of Extension Cord
0-6	240	up to 50	18 AWG
0-6	240	50-100	16 AWG
0-6	240	100-200	16 AWG
0-6	240	200-300	14 AWG
6-10	240	up to 50	18 AWG
6-10	240	50-100	16 AWG
6-10	240	100-200	14 AWG
6-10	240	200-300	12 AWG
10-12	240	up to 50	16 AWG
10-12	240	50-100	16 AWG
10-12	240	100-200	14 AWG
10-12	240	200-300	12 AWG
12-16	240	up to 50	14 AWG
12-16	240	50-100	12 AWG
12-16	240	GREATER THAN 100 FEET NOT RECOMMENDED	

Fig. D-2

FUNCTIONAL DESCRIPTION

FOREWORD

Delta ShopMaster Model TS220LS has big saw capacity at an economical price. The Delta ShopMaster Model TS220LS has an extra large, 17½"x34" aluminum table and is powered by a heavy-duty 15 amp. motor with a floating jackshaft gear - the most powerful in its class. This saw is designed to give high quality performance with depth of cut capacity up to 3" (76mm) at 90° and 2" (51mm) at 45° for clean cutting of standard stock sizes. This package includes the saw, a metal stand, rip fence, miter gage, see-through blade guard with splitter and anti-kickback fingers, a 10" carbide-tipped saw blade, table insert and blade wrenches.

UNPACKING AND CLEANING

Carefully unpack the machine and all loose items from the shipping container(s). Remove the protective coating from all unpainted surfaces. This coating may be removed with a soft cloth moistened with kerosene (do not use acetone, gasoline or lacquer thinner for this purpose). After cleaning, cover the unpainted surfaces with a good quality household floor paste wax.

NOTICE: THE PHOTO ON THE MANUAL COVER ILLUSTRATES THE CURRENT PRODUCTION MODEL. ALL OTHER ILLUSTRATIONS CONTAINED IN THE MANUAL ARE REPRESENTATIVE ONLY AND MAY NOT DEPICT THE ACTUAL COLOR, LABELING OR ACCESSORIES AND ARE INTENDED TO ILLUSTRATE TECHNIQUE ONLY.

ASSEMBLY

TABLE SAW PARTS

- 1- Saw
- 2- Extension Wing
- 3- 1/4" - Flat Washer for Mounting Extension Wing (3)
- 4- 1/4" - Lockwasher for Mounting Extension Wing (3)
- 5- 1/4-20 x 5/8" Hex Head Screw for Mounting Extension Wing (3)

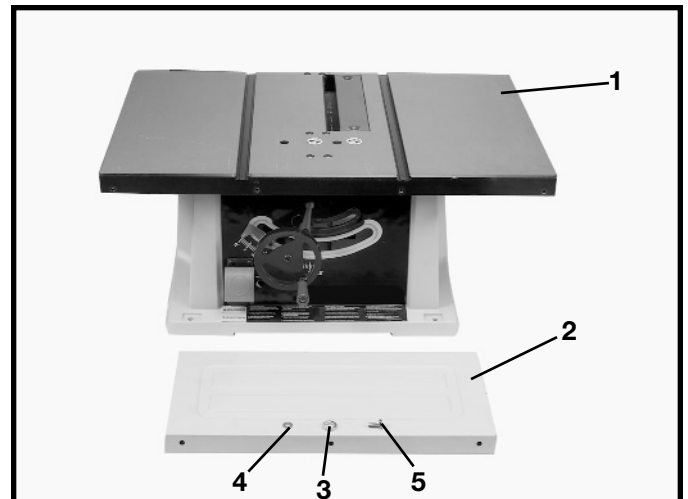

Fig. 2

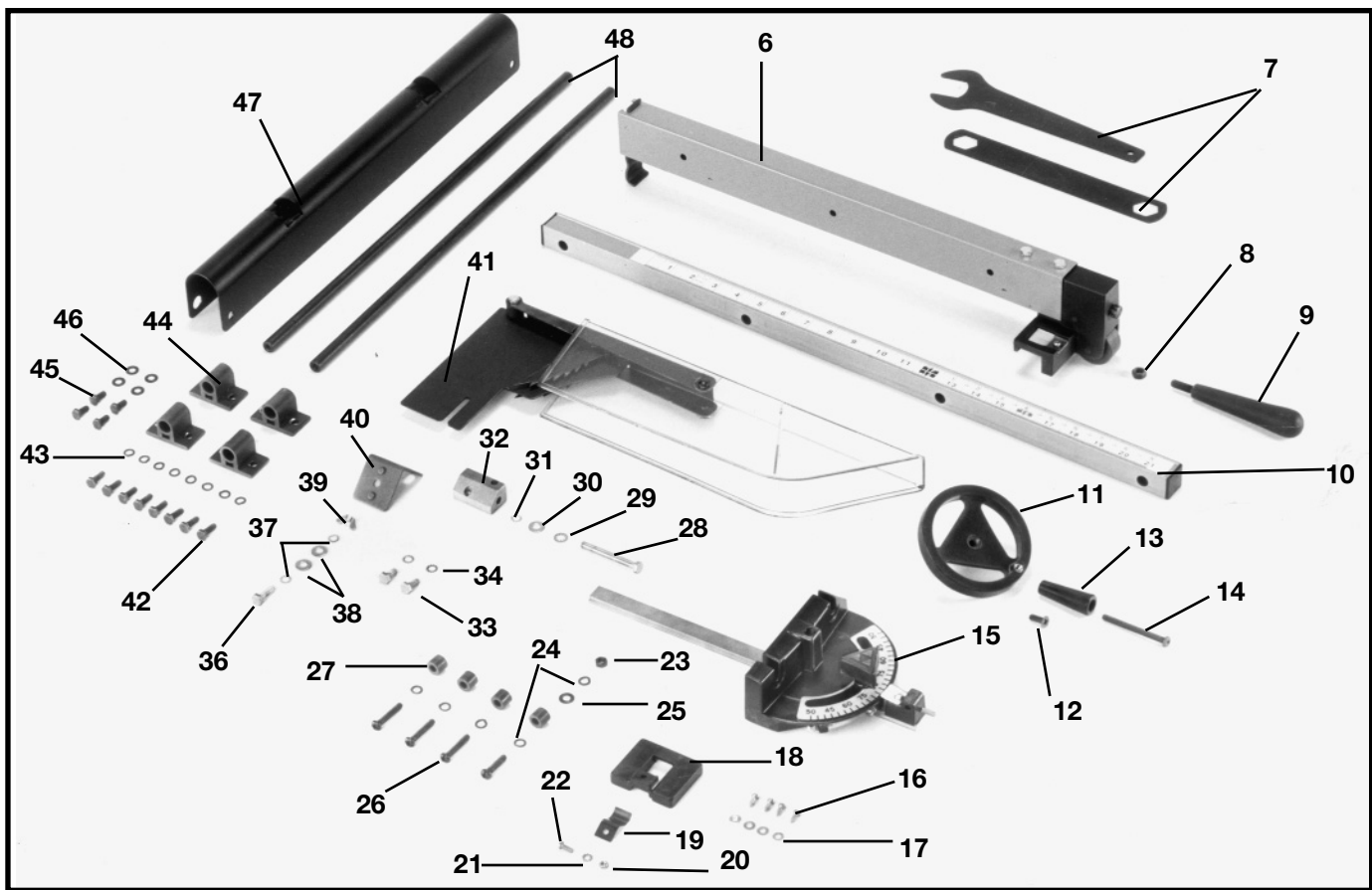

Fig. 3

- 6 - Rip Fence
- 7 - Wrenches for Blade Changing
- 8 - M8x1.25 Hex Nut for Rip Fence
- 9 - Locking Handle for Rip Fence
- 10 - Fence Rail
- 11 - Blade Raising and Lowering Handwheel
- 12 - M6x1x12mm Flat Head Screw for Mounting Blade Raising and Lowering Handwheel
- 13 - Handle for Blade Raising and Lowering Handwheel
- 14 - M6x1x55mm Cheese Head Screw for Mounting Handwheel Handle
- 15 - Miter Gage
- 16 - M4.2x10mm Pan Head Screws for Mounting miter gage Holder (4)
- 17 - 3/16" Flat Washers for Mounting Miter Gage Holder (4)
- 18 - Miter Gage Holder
- 19 - Spring Clip for Miter Gage Holder
- 20 - M4x.7 Hex Nut for Miter Gage Holder
- 21 - 3/16" External Tooth Lockwasher for Miter Gage Holder
- 22 - M4x.7x10mm Pan Head Screw for Miter Gage Holder
- 23 - 1/4-20 Hex Nut for Mounting Fence Rail to Extension Wing
- 24 - 1/4" Lockwashers for Mounting Fence Rail (5)
- 25 - 1/4" Flat Washer for Mounting Fence Rail to Extension Wing
- 26 - 1/4-20 x 1-1/4" Round Head Screws for Mounting Fence Rail (4)
- 27 - Spacer for Mounting Fence Rail (4)
- 28 - 1/4-20 x 2-1/4" Long Hex Head Screw for Mounting Splitter Bracket
- 29 - 1/4" Internal Tooth Lockwasher for Mounting Splitter Bracket
- 30 - 1/4" Flat Washer for Mounting Splitter Bracket
- 31 - 1/4" External Tooth Lockwasher for Mounting Splitter Bracket
- 32 - Splitter Bracket
- 33 - 1/4-20 x 1/2" Hex Head Screws for Splitter Bracket (2)
- 34 - 1/4" External Tooth Lockwashers for Splitter Bracket (2)
- 36 - M6x1x20mm Hex Head Screw for Mounting Splitter Support Bracket
- 37 - 1/4" External Tooth Washers for Mounting Splitter Support Bracket (2)
- 38 - 1/4" Flat Washers for Mounting Splitter Support Bracket (2)
- 39 - Wing Nut for Mounting Splitter Support Bracket
- 40 - Splitter Support Bracket
- 41 - Splitter and Guard Assembly
- 42 - M6x1x15mm Hex Head Screw for Mounting Outfeed Support Brackets (8)
- 43 - M6.1 Lockwasher for Mounting Outfeed Support Brackets (8)
- 44 - Outfeed Support Bracket (4)
- 45 - 1/4-20x1/2" Hex Head Screw for Mounting Rear Support onto Support Rods (4)
- 46 - 1/4" Flat Washer for Mounting Rear Support onto Support Rods (4)
- 47 - Rear Support
- 48 - Support Rod (2)

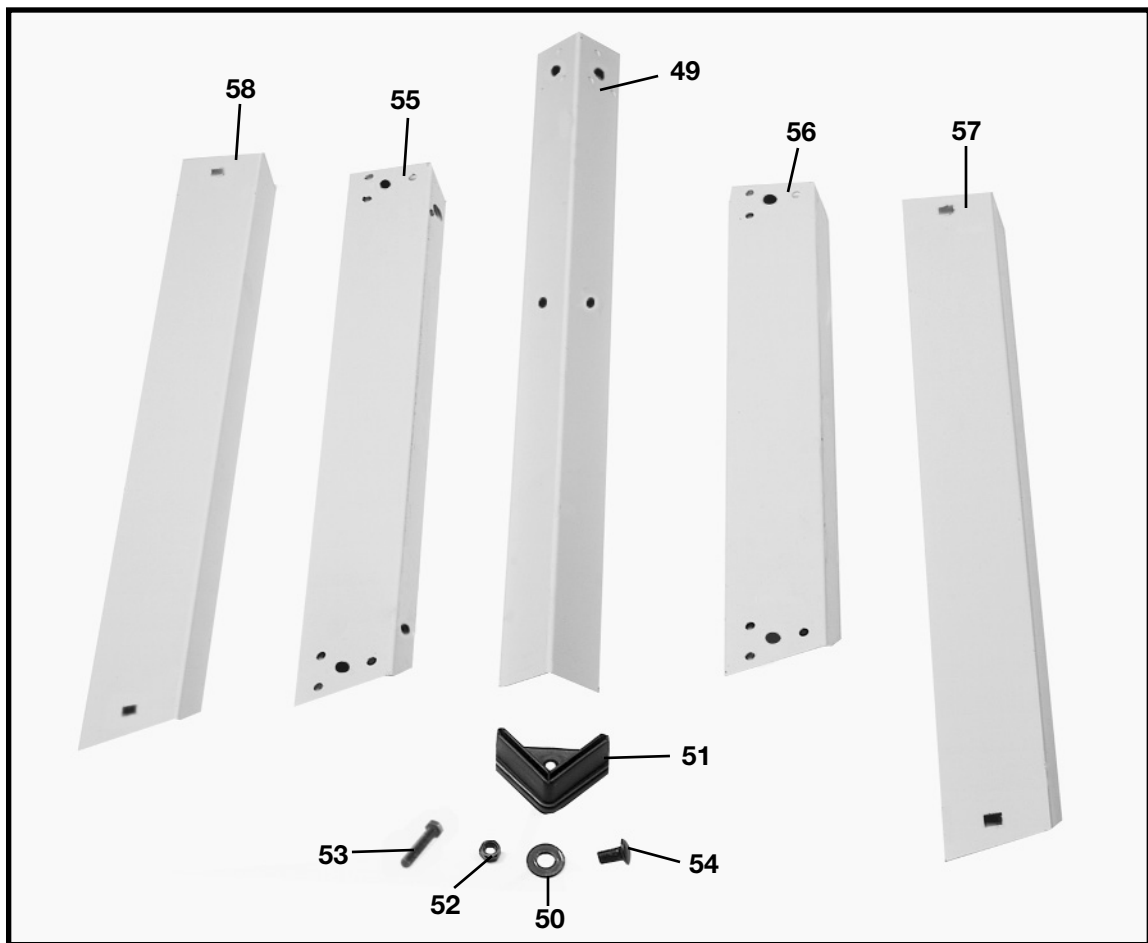

Fig. 4

STAND PARTS

49 - Leg (4)

50 - 3/8" Flat Washer for Mounting Saw to Stand & for Assembling Stand (24)

51 - Foot (4)

52 - M8x1.25 Hex Nut for Mounting Saw to Stand & for Assembling Stand (20)

53 - M8x1.25x40mm Hex Screw for Mounting Saw to Stand (4)

54 - M8x1.25x20mm Carriage Bolts for Assembling Stand (16)

55 - 18-1/2" Top Front and Rear Brackets (2)

56 - 17" Top Side Brackets (2)

57 - 22" Bottom Front and Rear Brackets (2)

58 - 20-3/8" Bottom Side Brackets (2)

⚠ WARNING FOR YOUR OWN SAFETY, DO NOT CONNECT THE MACHINE TO THE POWER SOURCE UNTIL THE MACHINE IS COMPLETELY ASSEMBLED. DO NOT OPERATE THIS MACHINE UNTIL YOU READ AND UNDERSTAND THE ENTIRE INSTRUCTION MANUAL

STAND ASSEMBLY

1. Assemble the stand as shown in Fig. 4A, using 16 carriage bolts, flat washers and hex nuts. Do not completely tighten the hardware at this time. Letters are stamped on the stand brackets for ease in assembly.

A - Top front and rear brackets

B - Top side brackets

C - Bottom side brackets

D - Bottom front and rear brackets

IMPORTANT: THE TOP FRONT AND REAR BRACKETS (A) FIG. 4A, ARE LONGER THAN THE TOP SIDE BRACKETS (B) FIG. 4A. THE BOTTOM FRONT AND REAR BRACKETS (D) FIG. 4A, ARE LONGER THAN THE BOTTOM SIDE BRACKETS (C).

2. Assemble the rubber feet (E) Fig. 4A, to the bottom of each leg (F) as shown. **NOTE:** Each rubber foot is provided with holes for mounting the stand to the floor surface if required.

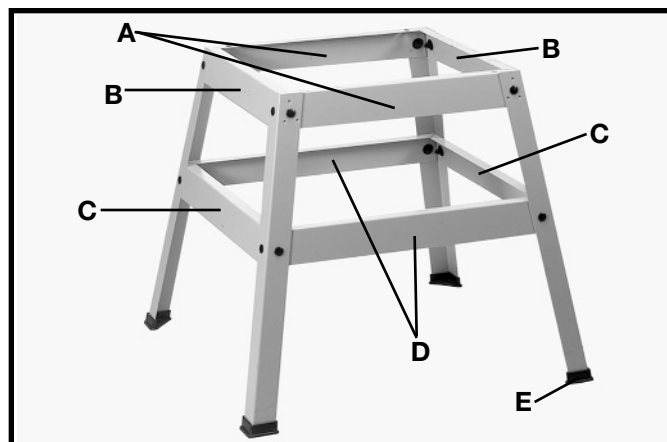

Fig. 4A

SAW TO STAND

1. Turn saw table face down on a piece of cardboard to protect the table surface. Place stand upside down onto saw and align the four holes in the stand with the mounting holes in the saw.

2. Place a 3/8" flat washer on a M8x1.25x40mm hex head screw. Insert the hex head screw through the mounting hole in the saw and the mounting hole in the stand. Place another 3/8" flat washer on the hex head screw and thread a M8x1.25 hex nut on the screw and loosely tighten. Complete this process for the other three holes.

3. Then, turn saw table face up, as shown in Fig. 4B (Saw is shown fully assembled here).

3. Push down on top of the saw so the legs of the stand adjust to the surface of the floor and tighten all stand hardware and hardware which secures saw to stand.



Fig. 4B

ASSEMBLING BLADE RAISING AND LOWERING HANDWHEEL

1. Insert M6x1x55mm cheese head screw (14) Fig. 3, through handle (E) Fig. 5 and assemble handle (E) to handwheel (A) by threading screw (D) Fig. 5 clockwise into handwheel.

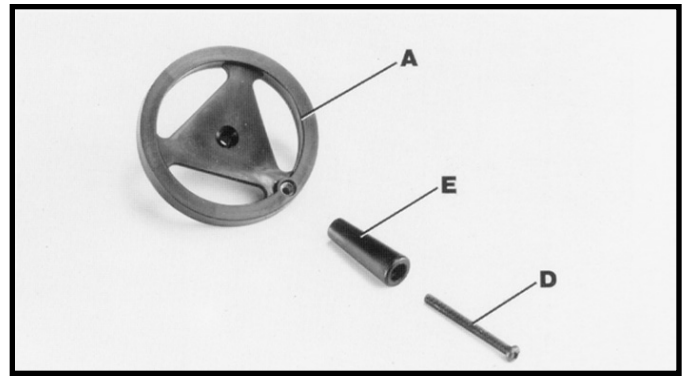

Fig. 5

2. Fig. 6, illustrates the handle (E) assembled to handwheel (A).

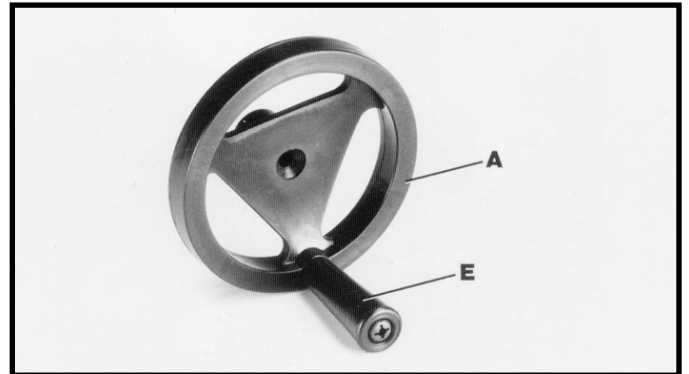

Fig. 6

3. Assemble handwheel (A) Fig. 7, to shaft (B) making sure the flat on inside of handwheel lines up with flat on shaft.

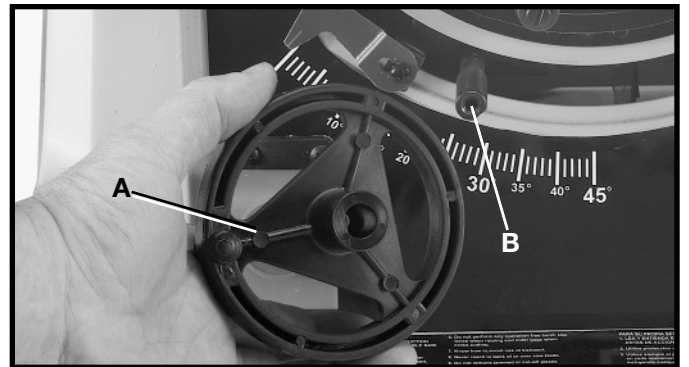

Fig. 7

4. Fasten handwheel (A) Fig. 8, to shaft (B) Fig. 7, using a M6x1x12mm flat head screw (C) Fig. 8.

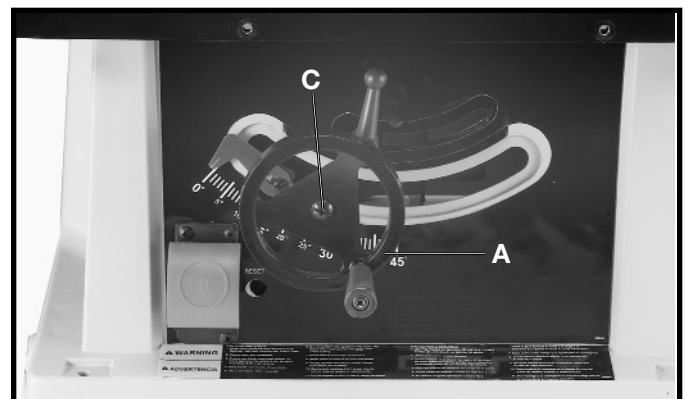

Fig. 8

BLADE GUARD AND SPLITTER ASSEMBLY

⚠ WARNING DISCONNECT MACHINE FROM POWER SOURCE.

1. **IMPORTANT: THE BLADE GUARD AND SPLITTER ASSEMBLY MUST BE PROPERLY ALIGNED TO THE SAW BLADE IN ORDER TO PREVENT KICKBACK.**

2. Position the blade 90 degrees to the table and lock in place.

3. Fasten the splitter support bracket (A) Fig. 9, to splitter bracket (B) using two 1/4-20 x 1/2" Hex Head Screws (C), and two 1/4" external tooth lockwashers as shown. **NOTE: Do not completely tighten screws (C) at this time.**

4. Locate the 1/4-20 x 2-1/4" hex head screw (G) Fig. 10, and assemble the 1/4" internal tooth lockwasher (O), 1/4" flat washer (P) and 1/4" external tooth lockwasher (R) onto screw (G).

5. Position recessed end (E) Fig. 11, of splitter bracket (B) against end of pivot rod (F) and fasten in place using assembly from STEP 4. **NOTE: Do not completely tighten screw (G) at this time.**

6. Position the splitter (H) Fig. 13, on the splitter support bracket as shown, making certain the two protrusions (K) on the splitter support bracket are inside the slot of splitter (H).

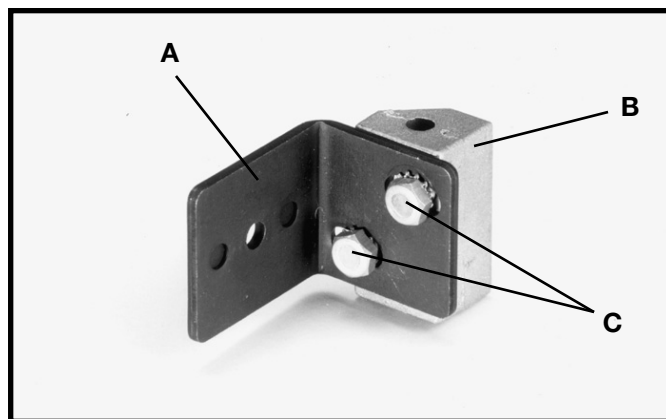

Fig. 9

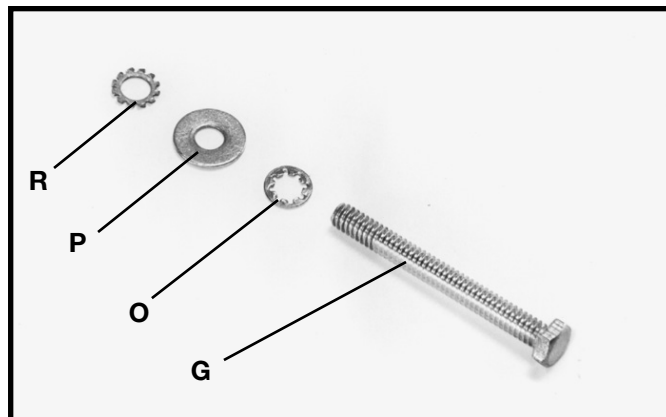

Fig. 10

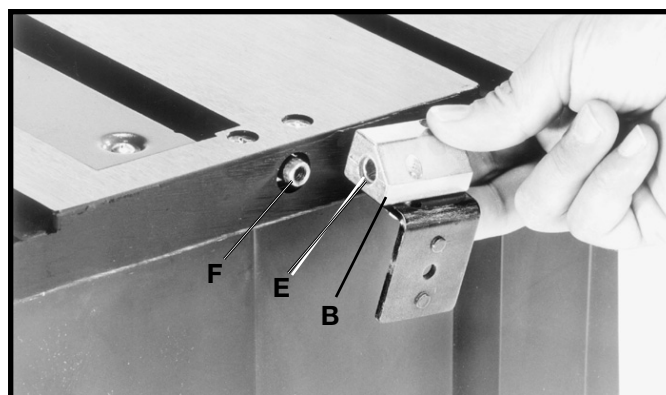

Fig. 11

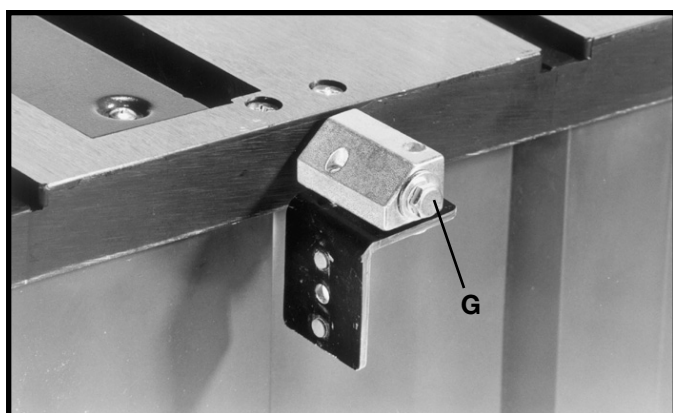

Fig. 12

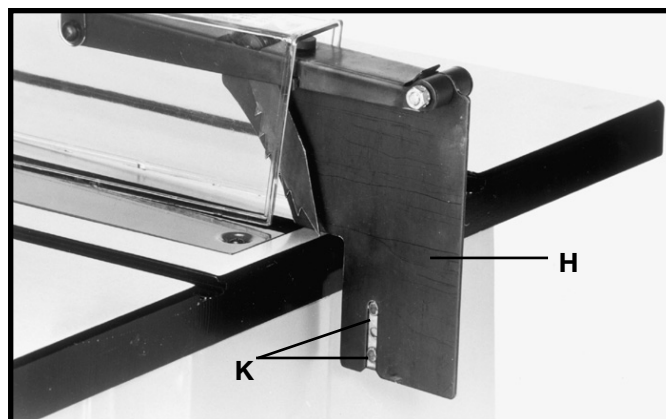

Fig. 13

7. Assemble splitter (H) Fig. 14, to splitter support bracket (B) as shown using M6x1x20mm hex head screw (L), 1/4" external tooth washer, and 1/4" flat washer.

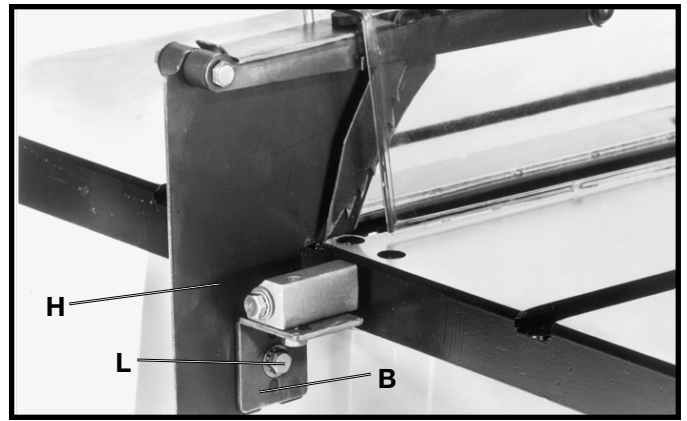

Fig. 14

8. Fasten splitter (H) Fig. 15, to splitter support bracket using 1/4" flat washer, 1/4" external tooth lockwasher and M6 wing nut (M). **NOTE:** Before tightening wing nut (M) make certain there is at least a 1/8" gap between the bottom edge of splitter (N) and top surface of table (P) and that protrusion "pins" (K) Fig. 15, are inside the slot of splitter assembly (H).

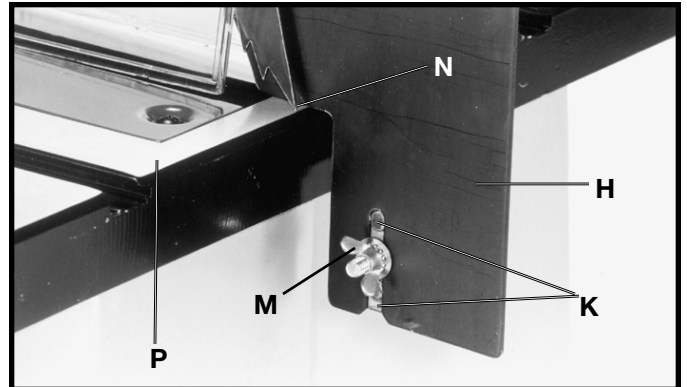

Fig. 15

9. Using a straight edge, check to see if the splitter (H) Fig. 16, is aligned with the saw blade (R). If an adjustment is necessary, the splitter (H) can be moved left or right and rotated.

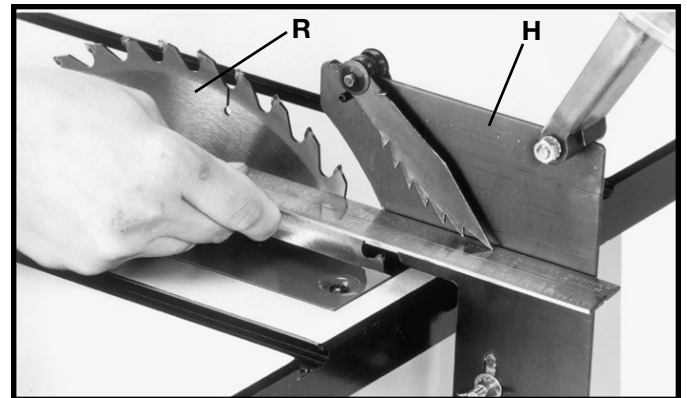

Fig. 16

10. When you are certain the splitter is properly aligned with the saw blade, tighten the two screws (C) Fig. 17, that fasten the splitter support bracket to the splitter bracket and tighten screw (G) that fastens the splitter bracket to the pivot rod.



Fig. 17

EXTENSION WING

1. Assemble extension wing (A) Fig. 18, to the saw table using three 1/4-20 x 5/8" hex head screws (B), 1/4" lockwashers (C), and 1/4" flat washers (D).
2. With a straight edge (E) Fig. 19, make certain the top, front and rear edges of the extension wing (A) are level with the saw table before tightening three screws which secure extension wing to saw table.

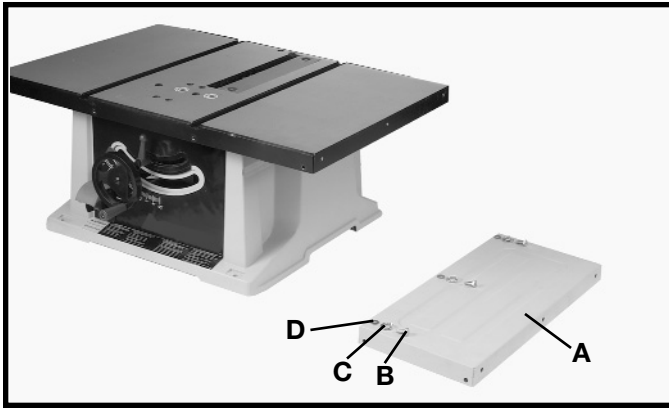

Fig. 18

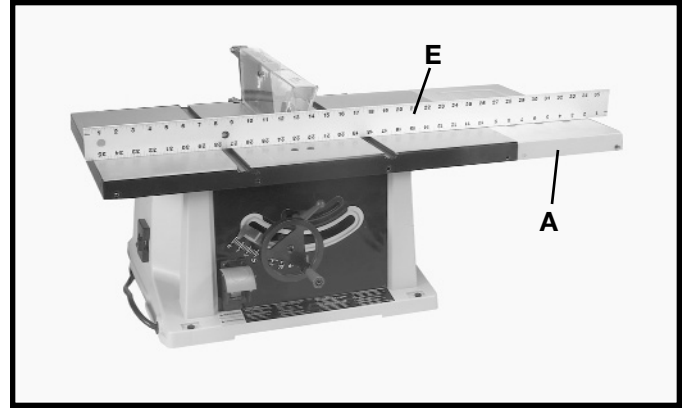

Fig. 19

GUIDE RAIL TO SAW

1. Loosely fasten guide rail (A) Fig. 20, to three threaded holes (B) in saw table (C) using three 1/4-20 x 1-1/4" long screws (D), 1/4" lockwashers (E), and spacers (F). **IMPORTANT: Spacers (F) Fig. 20, are positioned between guide rail (A) and saw table (C).**

2. Fasten guide rail (A) Fig. 20, to extension wing (G) through hole (K) using the 1/4-20 x 1-1/4" long screw (D), 1/4" lockwasher (E), spacer (F), 1/4" flat washer (H), 1/4" lockwasher (E), and 1/4-20 hex nut (J). Then tighten all guide rail mounting hardware.

IMPORTANT: Spacer (F) Fig. 20, is positioned between guide rail (A) and extension wing (G).

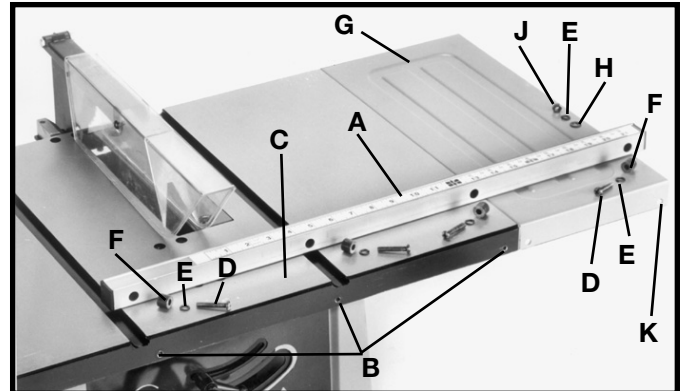

Fig. 20

3. Fig. 21, illustrates the guide rail properly assembled to saw table and extension wing.



Fig. 21

RIP FENCE

1. Thread an M8 hex nut (A) Fig. 22, approximately halfway onto stud of handle (B).
2. Thread handle (B) Fig. 22, into tapped hole (C) in fence cam (D). Tighten hex nut (A) Fig. 23, against cam (D).

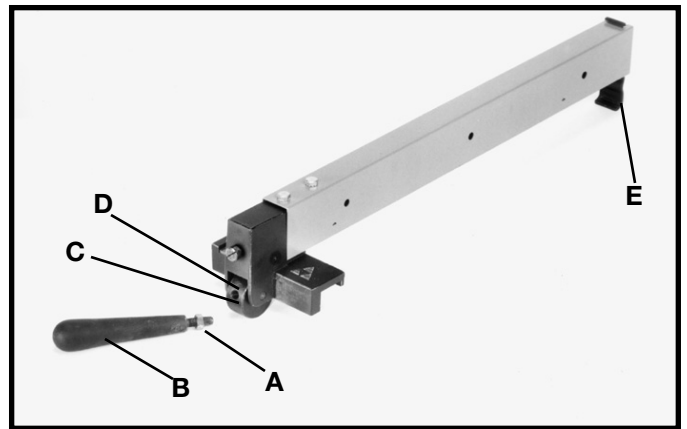

Fig. 22

3. Lower rip fence onto table as shown in Fig. 24, making certain rear clamp (E) Fig. 22, hooks over back edge of table.

4. The rip fence is usually operated on the right hand side of the saw table. Lift lock handle (B) Fig. 24, and position fence on table as shown. Push downward on handle (B) Fig. 24, to lock fence in place on saw table.

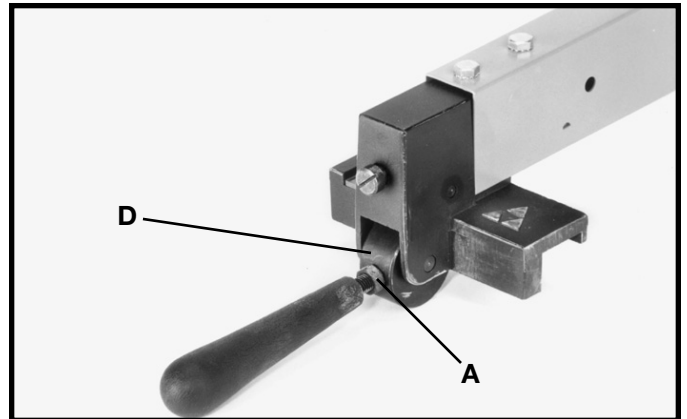

Fig. 23

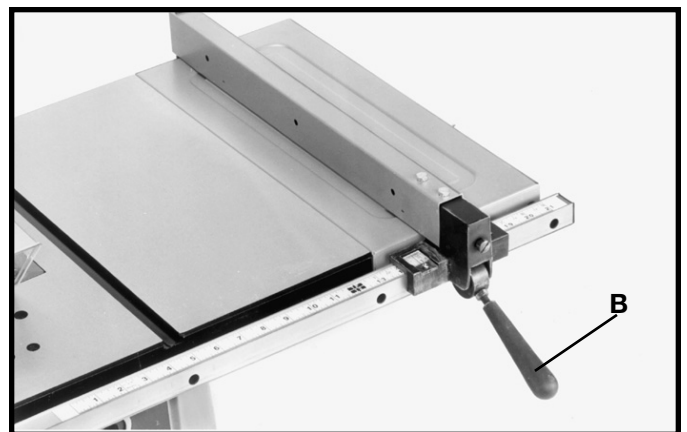

Fig. 24

MITER GAGE

The miter gage is shipped completely assembled and is supplied with a T-slot miter gage bar (A) Fig. 25, that is inserted into either one of the two T-slotted miter gage grooves located in the table top, as shown. The T-slot miter gage prevents the miter gage from falling when it is extended out beyond the front of the table when cross-cutting extra wide workpieces.

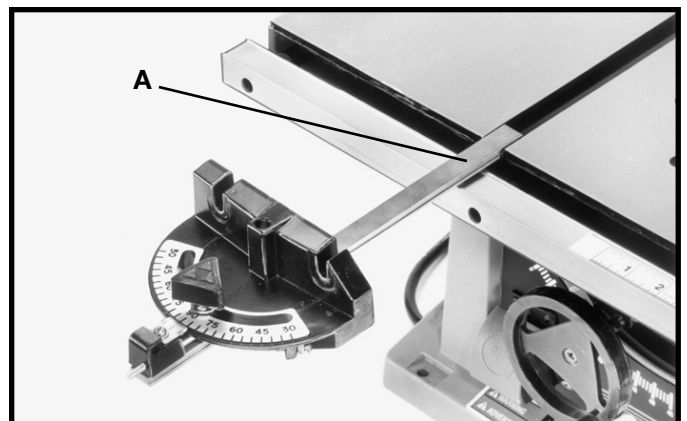

Fig. 25

MITER GAGE HOLDER

⚠ WARNING

DISCONNECT MACHINE FROM POWER SOURCE.

1. Assemble spring clip (E) Fig. 26, to the miter gage holder (A) as shown using a M4x.7x10mm pan head screw (F), 3/16" lockwasher and M4x.7 hex nut. **NOTE:** Hex nut (G) Fig. 27, will fit into the recess at the back of the miter gage holder (A) to keep spring clip (E) Fig. 26, secured to the miter gage holder.

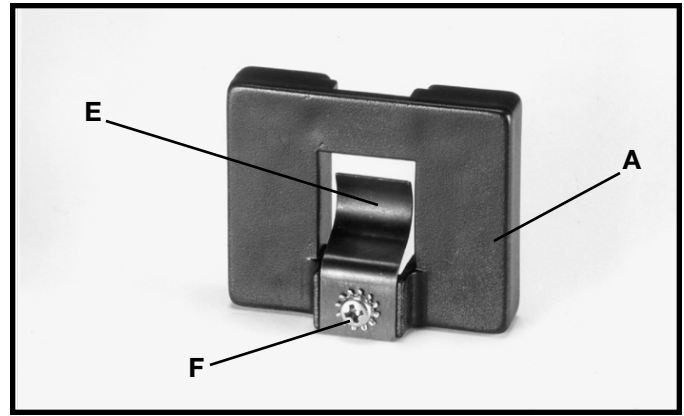

Fig. 26

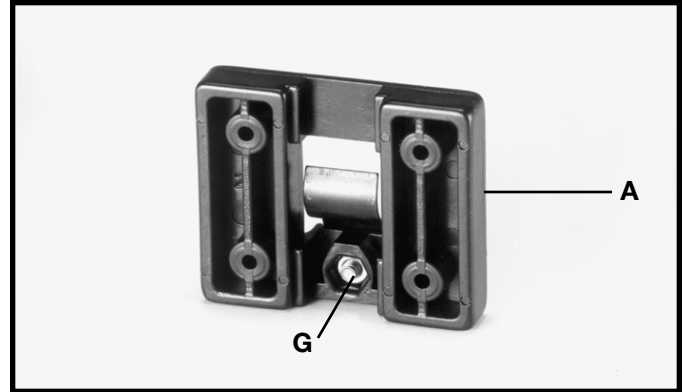

Fig. 27

2. Assemble the miter gage holder (A) Fig. 28, to the left side of the saw cabinet using the four M4.2x10mm pan head screws (B) Fig. 29, and 3/16" washers (C) from inside saw cabinet.

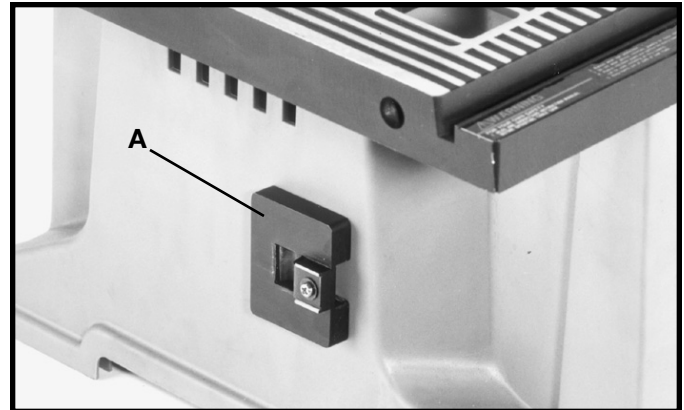

Fig. 28

3. Fig. 30, illustrates the miter gage (D) inserted into the miter gage holder when not in use.

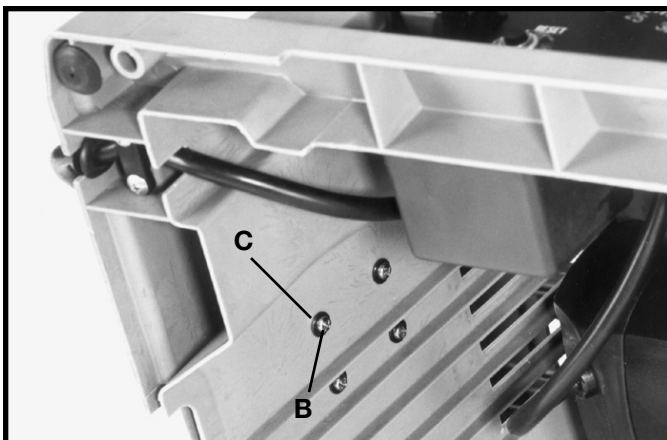

Fig. 29

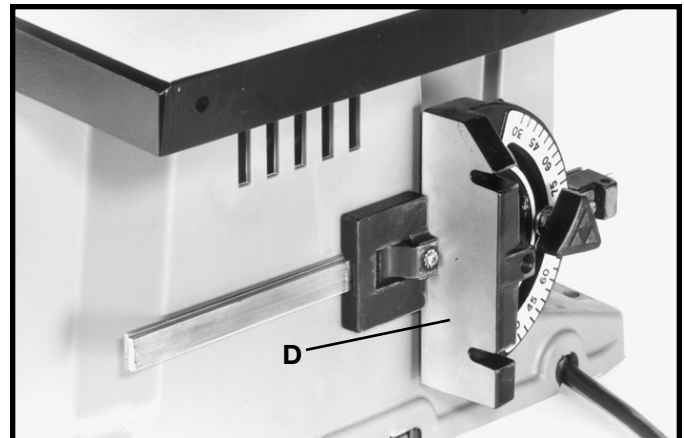

Fig. 30

OUTFEED SUPPORT

1. Loosely fasten both brackets (A) Fig. 31, to the bottom left side of the saw table as shown, using two M6x1x15mm hex head screws (B) and M6.1 lockwashers (C). Assemble two remaining brackets to the bottom right side of saw table in the same manner.

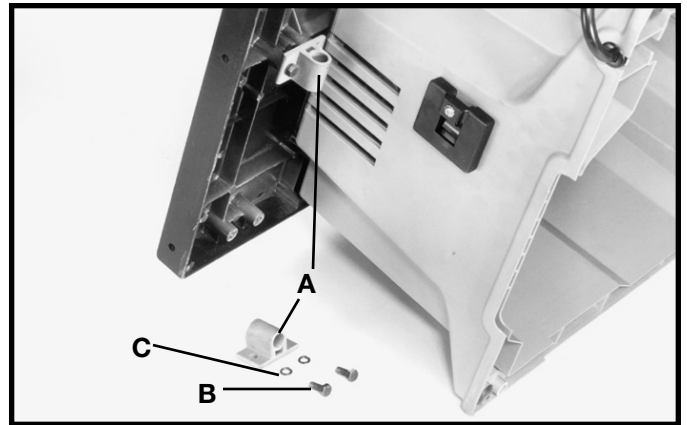

Fig. 31

2. Insert rod (D) Fig. 32, through holes in brackets (A) as shown. Then thread and tighten one 1/4-20x1/2" hex head screw (E) and 1/4" flat washer (F) into the front end of rod (D) as shown at (G). Assemble remaining rod to the opposite side of saw in the same manner.

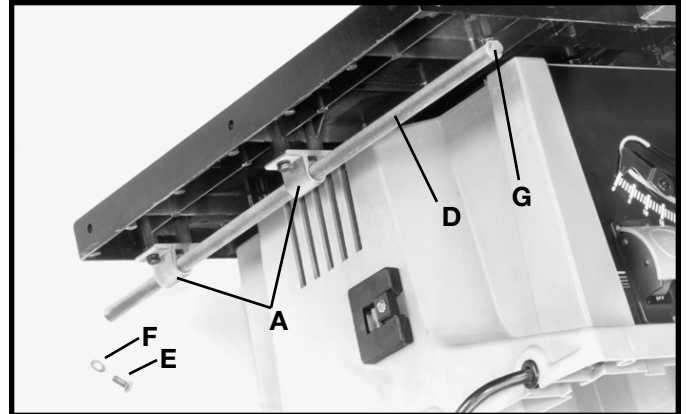

Fig. 32

3. Insert rods (D) Fig. 33, into larger holes (H) in outfeed support (J) as shown.

4. Secure outfeed support (J) Fig. 34, to rods (D) using two 1/4-20x1/2" hex head screws and 1/4" flat washers (K) as shown.

5. Push entire outfeed support assembly (J) Fig. 35, in until it contacts splitter/guard assembly (L) as shown. Then tighten all outfeed support mounting hardware.

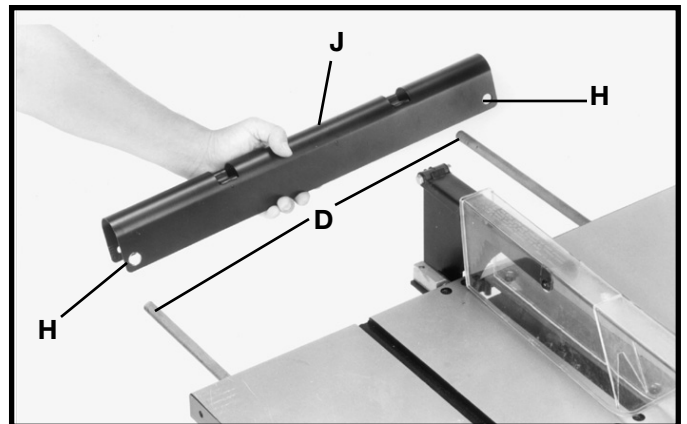

Fig. 33

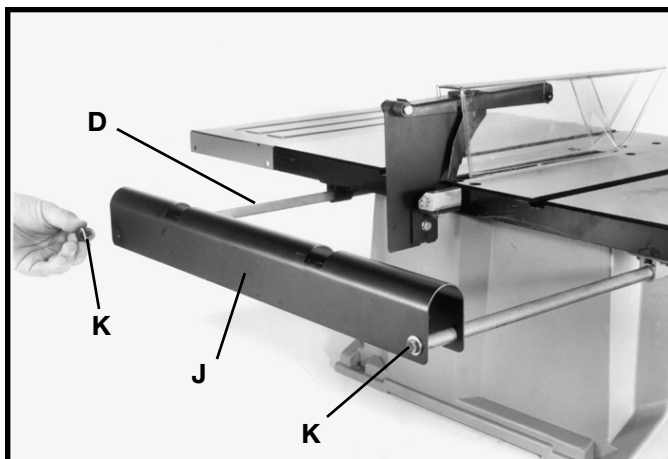

Fig. 34

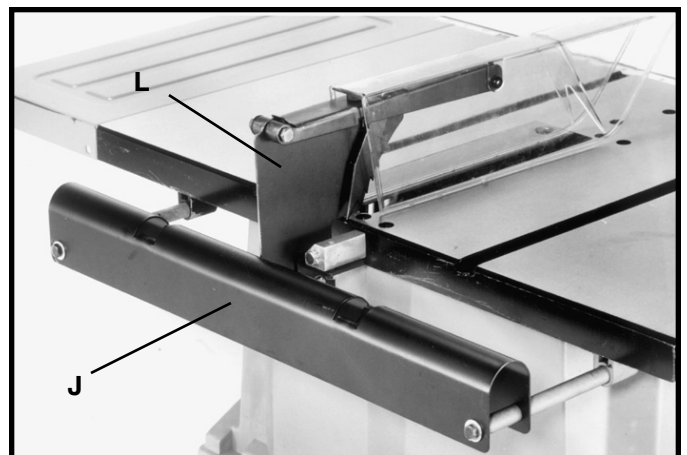

Fig. 35

OPERATING CONTROLS AND ADJUSTMENTS

STARTING AND STOPPING SAW

1. The on/off switch is located underneath the switch shield (A) Fig. 36. To turn the saw **“ON”**, move switch trigger (B) up to the **“ON”** position.

2. To turn the saw **“OFF”**, push down on switch shield (A) Fig. 37.

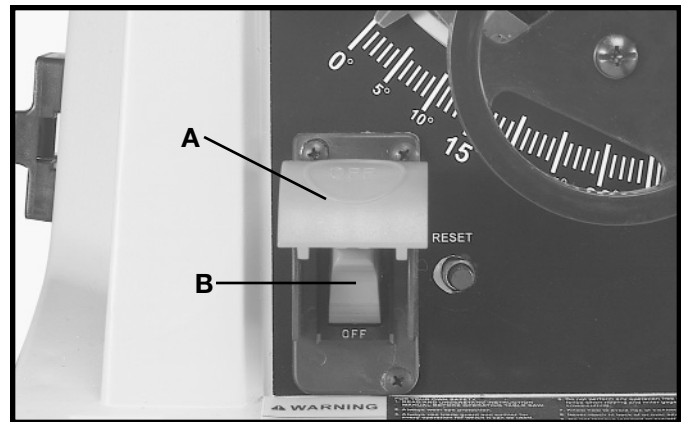

Fig. 36

LOCKING SWITCH IN THE “OFF” POSITION

IMPORTANT: WHEN THE TOOL IS NOT IN USE, THE SWITCH SHOULD BE LOCKED IN THE OFF POSITION USING A PADLOCK (C) FIG. 38, WITH A 3/16" DIAMETER SHACKLE TO PREVENT UNAUTHORIZED USE.

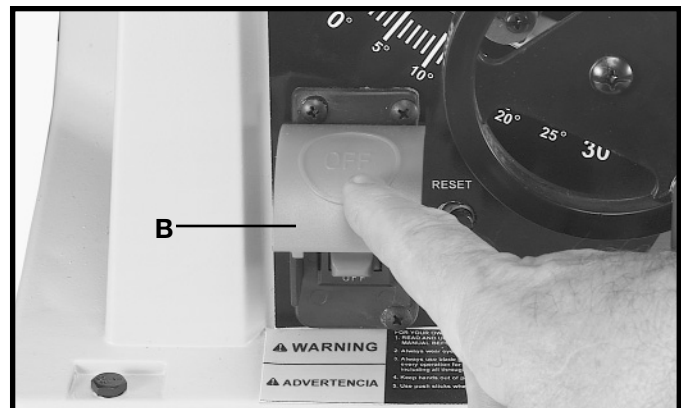

Fig. 37

OVERLOAD PROTECTION

Your saw is equipped with a reset overload relay button (C) Fig. 39. If the motor shuts off or fails to start due to over loading (cutting stock too fast, using a dull blade, using the saw beyond its capacity, etc.) or low voltage, turn the switch to the **“OFF”** position. Let the motor cool three to five minutes and push the reset button (C), which will reset the overload device. The motor can then be turned on again in the usual manner.

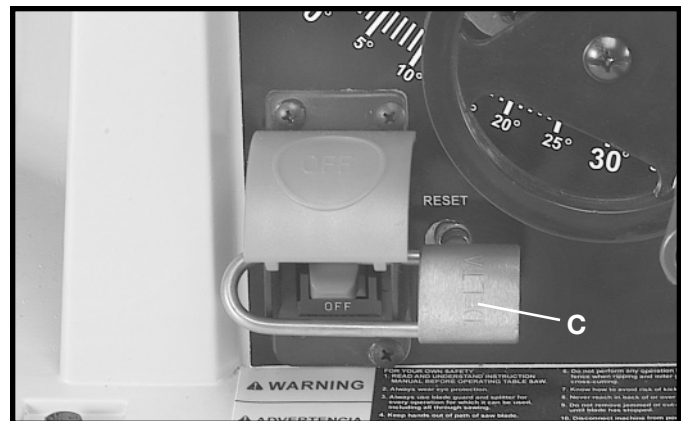

Fig. 38

BLADE RAISING AND LOWERING CONTROL

To raise or lower the saw blade, turn handwheel (A) Fig. 39. Turning the handwheel clockwise lowers the blade and turning the handwheel counterclockwise raises the blade.

⚠ WARNING THE BLADE TILTING LOCK HANDLE (B) FIG. 39, MUST BE LOCKED DURING ALL CUTTING OPERATIONS.

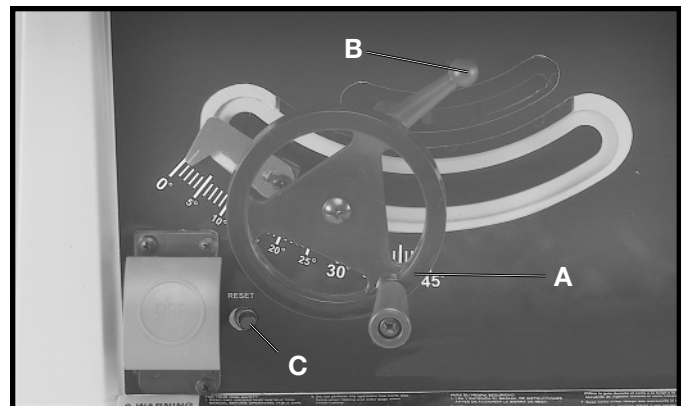

Fig. 39

BLADE TILTING CONTROL

To tilt the saw blade, loosen blade tilting lock handle (A) Fig. 40, move handwheel (B) until the blade is at the desired angle and tighten lock handle (A). **NOTE:** The lock handle (A) is spring-loaded and can be repositioned by pulling out on the handle (A) and repositioning it on the serrated stud located underneath the handle.

⚠ WARNING THE BLADE TILTING LOCK HANDLE (A) MUST BE LOCKED DURING ALL CUTTING OPERATIONS.

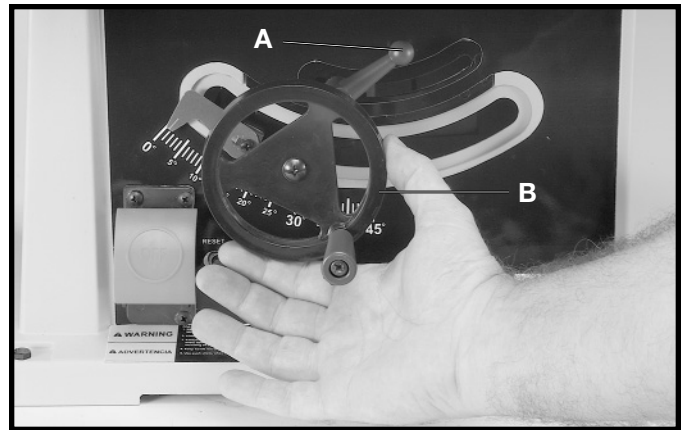

Fig. 40

ADJUSTING 90 AND 45 DEGREE POSITIVE STOPS

Your saw is equipped with positive stops for rapid and accurate positioning of the saw blade at 90 and 45 degrees to the table. To adjust the positive stops, proceed as follows:

⚠ WARNING DISCONNECT MACHINE FROM POWER SOURCE.

1. Raise the saw blade to its maximum height.

TO ADJUST POSITIVE STOP AT 90 DEGREES

2. Loosen the blade tilting lock handle, move the blade tilting mechanism as far as possible to the left and tighten the blade tilting lock handle.

3. Place a square (A) Fig. 41, on the table with one end of the square against the blade, as shown, and check to see if the blade is at 90 degrees to the table. If it is not, loosen screw (B) a few turns and move the blade tilting mechanism until the blade is at 90 degrees to the table. Then tighten blade tilting lock handle and tighten screw (B) until it bottoms.

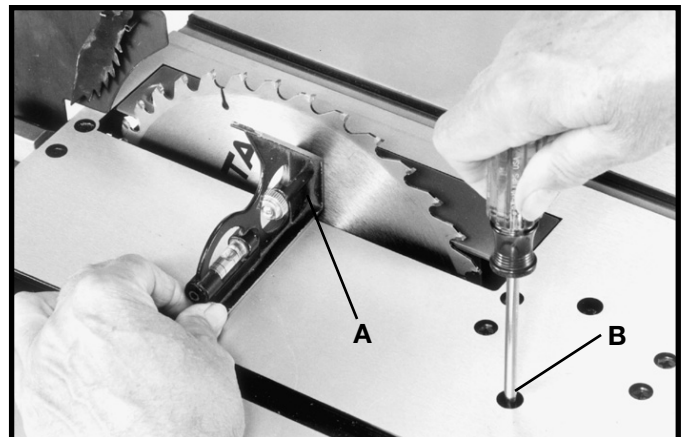

Fig. 41

TO ADJUST POSITIVE STOP AT 45 DEGREES

4. Loosen the blade tilting lock handle, move the blade tilting mechanism as far as possible to the right and tighten the blade tilting lock handle.

5. Place a square (A) Fig. 42, on the table with one end of the square against the blade as shown, and check to see if the blade is at 45 degrees to the table. If it is not, loosen screw (C) a few turns and move the blade tilting mechanism until the blade is at 45 degrees to the table. Then tighten blade tilting lock handle and tighten screw (C) until it bottoms.

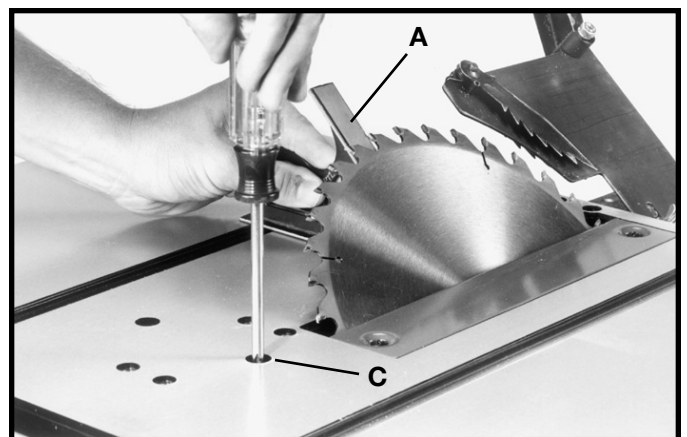

Fig. 42

RIP FENCE OPERATION AND ADJUSTMENTS

1. To move the rip fence (A) Fig. 43, along the table, lift up fence locking lever (B), slide the fence to the desired location on the table and push down fence locking lever (B) to lock the fence in position.

2. A pointer is supplied to indicate the distance the fence is positioned away from the saw blade. If an adjustment to the pointer is required, loosen the screw (C) Fig. 43, that fastens the pointer to the fence bracket and adjust the pointer accordingly. Then, tighten screw (C).

3. **IMPORTANT: THE RIP FENCE MUST BE PROPERLY ALIGNED TO THE MITER GAGE SLOT IN ORDER TO HELP PREVENT KICKBACK WHEN RIPPING.**

4. The saw blade is set parallel to the miter gage slot at the factory and the fence must be parallel to the miter gage slot in order to do accurate work and prevent kickback when ripping. To check the alignment:

5. Position the fence at one end of the miter gage slot, as shown in Fig. 48. Clamp the fence to the table by pushing down the locking lever (B). The edge of the fence should then line up parallel with the miter gage slot.

6. If an adjustment is necessary, proceed as follows:

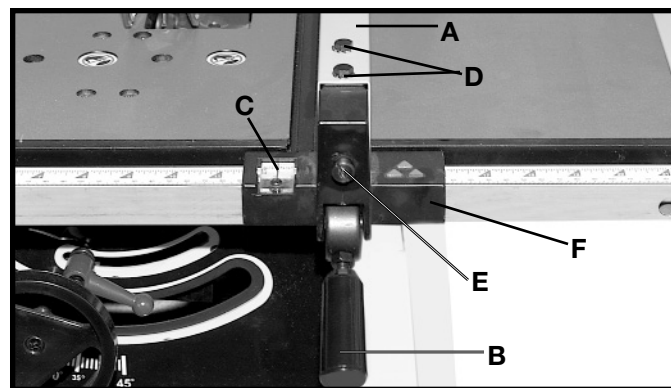

Fig. 43

7. Loosen the two screws (D) Fig. 43, and lift up locking lever (B). Then while holding the fence bracket (F) firmly toward the front of the saw, move the rear end of the fence (A) until it is parallel with the miter gage slot. Then tighten two screws (D) and push down locking lever (B).

8. The clamping action of the fence (A) Fig. 43, can be adjusted by lifting up locking lever (B) and turning screw (E) clockwise to increase or counterclockwise to decrease the clamping action of the fence.

MITER GAGE OPERATION AND ADJUSTMENTS

When straight cross-cutting (blade set 90 degrees to the table) the miter gage can be used in either table slot. When bevel cross-cutting (blade tilted) only use the miter gage in the right table slot where the blade is tilted away from the miter gage and your hands.

This miter gage is equipped with individually adjustable index stops at 90 degrees and 45 degrees right and left. Adjustment to the index stops can be made by loosening lock nuts (B) Fig. 49, and tightening or loosening the three adjusting screws (C) until they contact the other end of stop pin (D) when the miter gage is at 90 and 45 degrees to the saw blade. Then, tighten lock nuts (B).

To operate the miter gage, simply loosen lock knob (E) Fig. 44, and move the body of the miter gage to the desired angle. When the stop pin (D) is pushed in, the miter gage body will stop at 90 degrees and 45 degrees right and left. To rotate the miter gage body past these points, pull out stop pin (D).

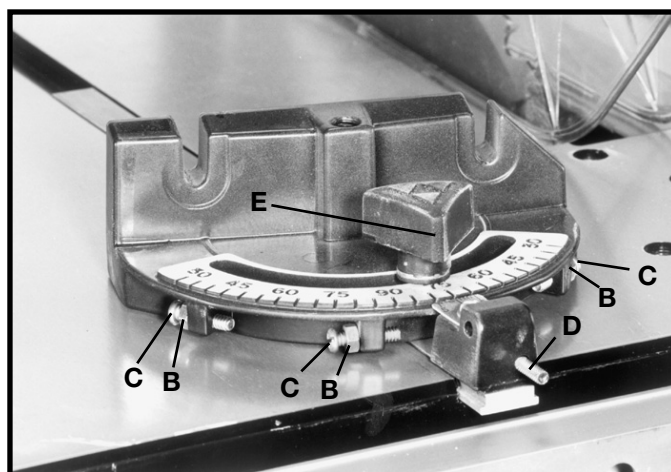

Fig. 44

ADJUSTING BLADE PARALLEL TO MITER GAGE SLOTS

The blade was adjusted parallel to the miter gage slots at the factory. In order to insure accurate cuts and help prevent kickback when cutting, this adjustment should be rechecked and if necessary, readjusted as follows:

1. **DISCONNECT MACHINE FROM POWER SOURCE.**
2. Raise the blade to its highest position and adjust the blade so it is 90 degrees to the table.
3. Select a tooth on the saw blade that is set to the left. Mark this tooth with a pencil or marker.
4. Using a combination square, place the body (A) Fig. 45, of the square against the miter gage slot and adjust the blade (B) of the square until it just touches the marked tooth, as shown.
5. Rotate the blade and check the same marked blade tooth at the rear of the saw table in the same manner, as shown in Fig. 46.
6. If the front and back measurements (Figs. 45 and 46) are not identical, you can adjust the blade. Start by loosening the nuts below the four screws (C) Fig. 47 on the table. Then loosen the screws (C). Carefully move the saw blade until the blade is parallel to the miter gauge slot. When done, tighten four nuts under the table and the four screws (C) Fig. 47 securely.

NOTE: If sufficient adjustment cannot be achieved by loosening screws (C), screws (D) may also be loosened if absolutely necessary to make the adjustment.

NOTE: Guard has been removed for illustrative purposes only.

CHANGING THE BLADE

DISCONNECT MACHINE FROM POWER SOURCE. USE ONLY 10" DIAMETER SAW BLADES RATED FOR 5000 RPM OR HIGHER WITH 5/8" ARBOR HOLES.



5000 RPM OR HIGHER WITH 5/8" ARBOR HOLES.

1. Raise the saw blade to its maximum height and remove the table insert (A) Fig. 48.
2. Using the open end wrench (B) Fig. 48, place open end of wrench on flats on inside blade flange to keep the saw arbor from rotating and remove arbor nut (C) with wrench (D). Turn nut (C) counterclockwise to remove. Remove outside blade flange (E) and saw blade (F).
3. Assemble new blade, making certain teeth of blade are pointing down at the front of the saw table and assemble the outside blade flange (E) Fig. 48, and arbor nut (C). Tighten nut (C) with wrench (D) by turning nut clockwise while holding arbor steady with other wrench (B).
4. Replace table insert.

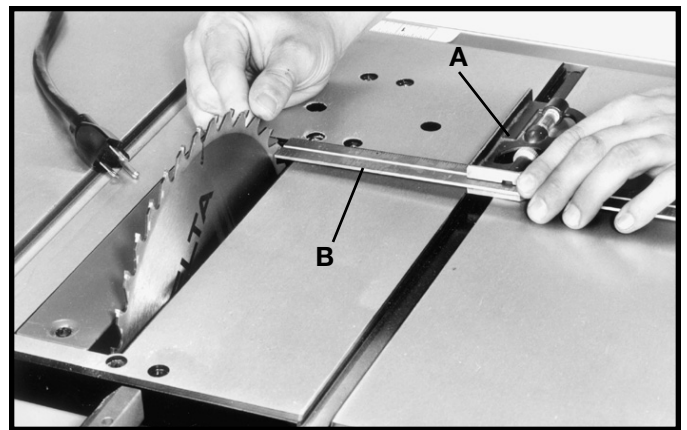

Fig. 45

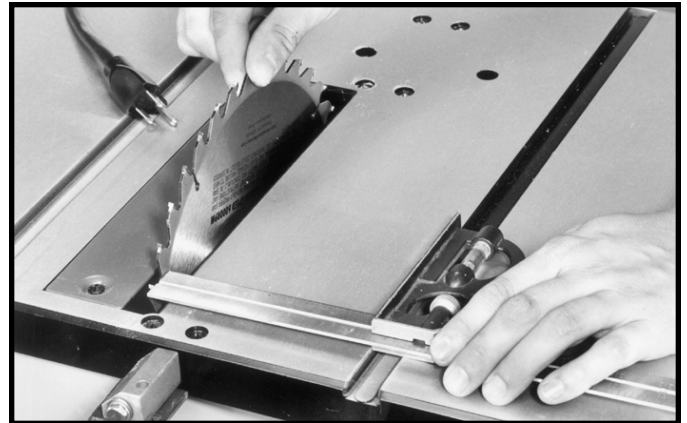

Fig. 46

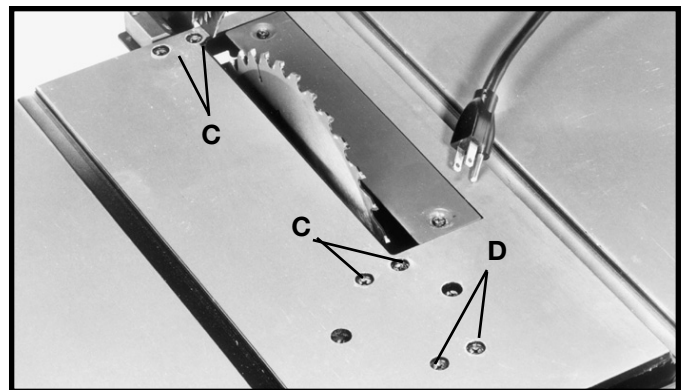

Fig. 47

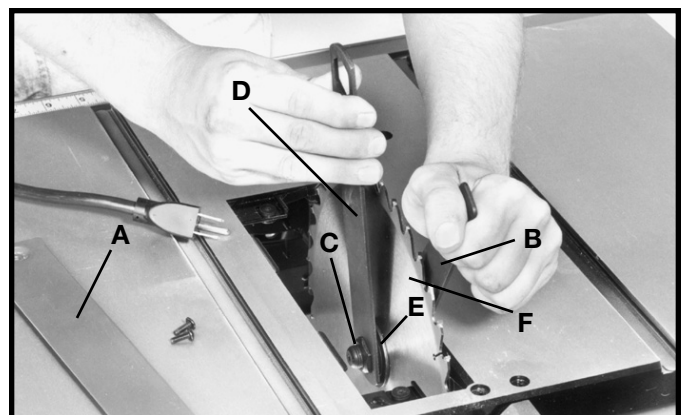

Fig. 48

COMMON SAWING OPERATIONS

Common sawing operations include ripping and crosscutting plus a few other standard operations of a fundamental nature. As with all power machines, there is a certain amount of hazard involved with the operation and use of the machine. Using the machine with the respect and caution demanded as far as safety precautions are concerned, will considerably lessen the possibility of personal injury. However, if normal safety precautions are overlooked or completely ignored, personal injury to the operator can result. The following information describes the safe and proper method for performing the most common sawing operations.

⚠ WARNING THE USE OF ATTACHMENTS AND ACCESSORIES NOT RECOMMENDED BY DELTA MAY RESULT IN THE RISK OF INJURY TO THE USER OR OTHERS.

CROSS-CUTTING

Cross-cutting requires the use of the miter gage to position and guide the work. Place the work against the miter gage and advance both the gage and work toward the saw blade, as shown in Fig. 49. The miter gage may be used in either table slot. When bevel cutting (blade tilted), use the table groove that does not cause interference of your hand or miter gage with the saw blade guard.

Start the cut slowly and hold the work firmly against the miter gage and the table. One of the rules in running a saw is that you never hang onto or touch a free piece of work. Hold the supported piece, not the free piece that is cut off. The feed in cross-cutting continues until the work is cut in two, and the miter gage and work are pulled back to the starting point. Before pulling the work back, it is good practice to give the work a little sideways shift to move the work slightly away from the saw blade. **Never** pick up any short length of free work from the table while the saw is running. **Never** touch a cut-off piece unless it is at least a foot long.

For added safety and convenience the miter gage can be fitted with an auxiliary wood-facing. This auxiliary wood-facing can be fastened to the front of the miter gage by using two wood screws through the slots (A) Fig. 49, provided in the miter gage body and into the wood-facing.

⚠ WARNING NEVER USE THE FENCE AS A CUT-OFF GAGE WHEN CROSS-CUTTING.

When cross-cutting a number of pieces to the same length, a block of wood (B) Fig. 49A can be clamped to the fence and used as a cut-off gage. It is important that this block of wood always be positioned in front of the saw blade as shown. Once the cut-off length is determined, secure the fence and use the miter gage to feed the work into the cut. This block of wood allows the cut-off piece to move freely along the table surface without binding between the fence and the saw blade, thereby lessening the possibility of kickback and injury to the operator.

⚠ CAUTION WHEN USING THE BLOCK (B) FIG. 49A, AS A CUT-OFF GAGE, IT IS VERY IMPORTANT THAT THE REAR END OF THE BLOCK BE POSITIONED SO THE WORK PIECE IS CLEAR OF THE BLOCK BEFORE IT CONTACTS THE BLADE.

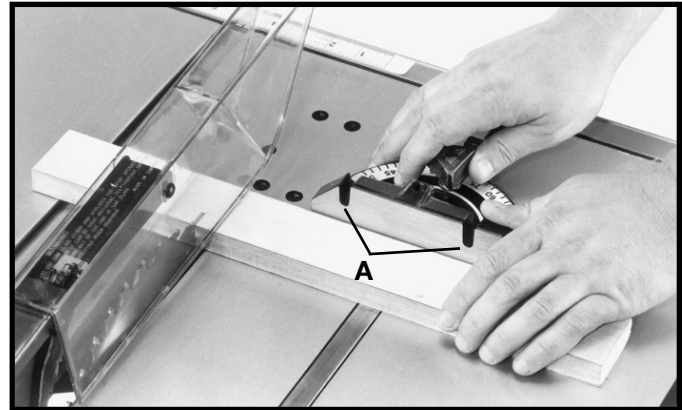

Fig. 49

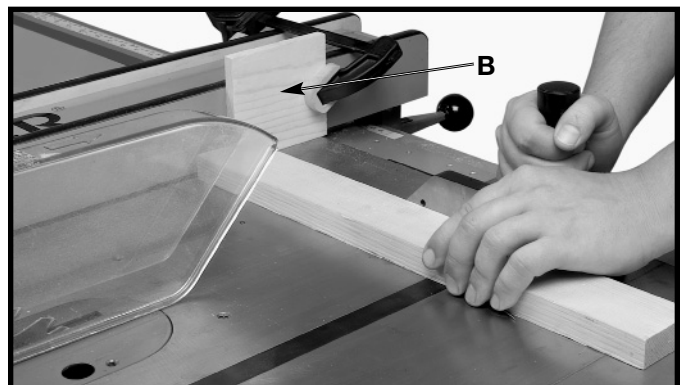

Fig. 49A

RIPPING

Ripping is cutting lengthwise through a board. The rip fence (A) Fig. 50 is used to position and guide the work. One edge of the work rides against the rip fence while the flat side of the board rests on the table. Since the work is pushed along the fence, it must have a straight edge and make solid contact with the table. The saw blade guard must be used. On Delta saws, the guard has anti-kickback fingers to prevent kickback and a splitter to prevent the wood kerf from closing and binding the blade.

1. Start the motor and advance the work holding it down and against the fence. **Never** stand in the line of the saw cut when ripping. Hold the work with both hands and push it along the fence and into the saw blade (Fig. 50). The work can then be fed through the saw blade with one or two hands. After the work is beyond the saw blade and anti-kickback fingers, the hand is removed from the work. When this is done the work will either stay on the table, tilt up slightly and be caught by the end of the rear guard, or slide off the table to the floor. Alternately, the feed can continue to the end of the table, after which the work is lifted and brought along the outside edge of the fence. The cut-off stock remains on the table and is not touched until the saw blade has stopped, unless it is a large piece allowing safe removal. When ripping boards longer than three feet, it is recommended that outfeed support (B) Fig. 50, should be extended as far out as possible to keep workpiece from falling off the saw table.

2. If the ripped work is less than 4 inches wide, a push stick should always be used to complete the feed, as shown in Fig. 51. The push stick can easily be made from scrap material as explained in the section **“CONSTRUCTING A PUSH STICK.”**

3. Ripping narrow pieces can be dangerous if not done carefully. Narrow pieces usually cannot be cut with the guard in position. If the workpiece is short enough, use a pushboard. When ripping material under 2 inches in width, a flat pushboard is a valuable accessory since ordinary type sticks may interfere with the blade guard. When using a pushboard, the width of the pushboard must be added to the width of the rip fence position setting. A flat pushboard can be constructed as shown in Fig. 53 and should be used as shown in Fig. 52

NOTE: Some special operations require the addition of an auxiliary wood facing to the fence, as explained in the section **“USING AUXILIARY WOOD FACING ON THE RIP FENCE”** and use of a push stick.

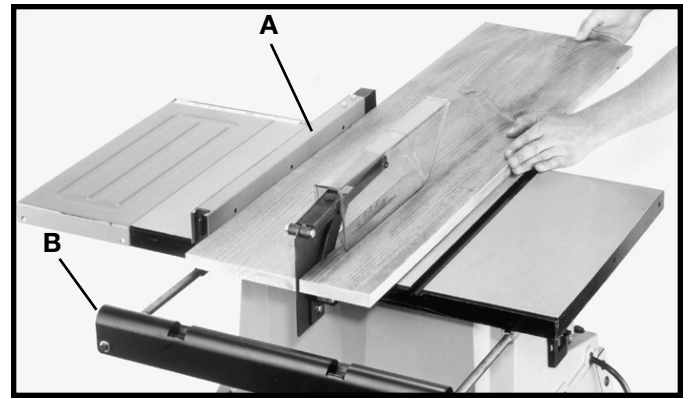

Fig. 50

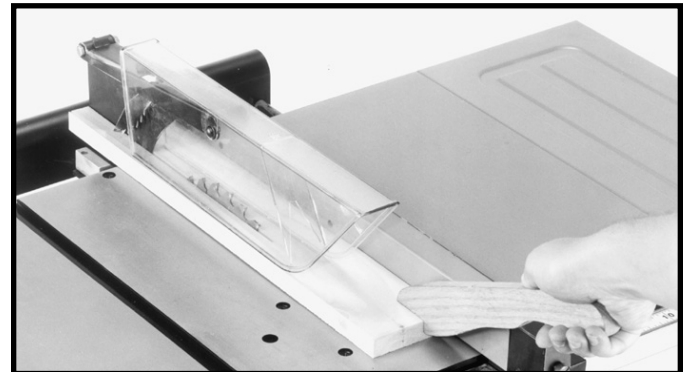

Fig. 51

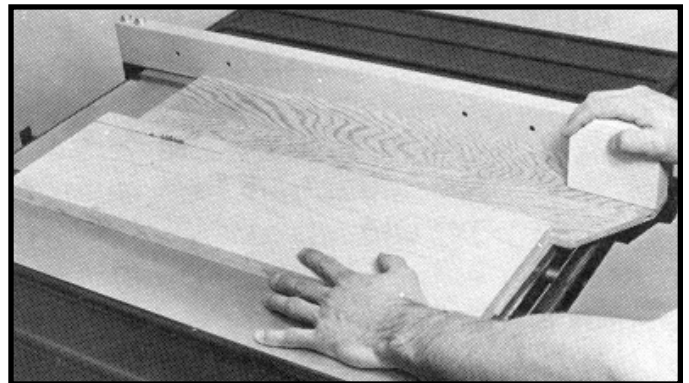

Fig. 52

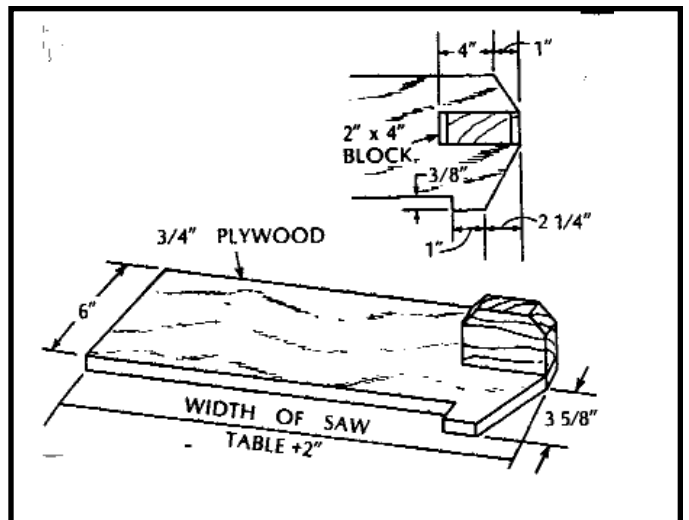

Fig. 53

USING AUXILIARY WOODFACING ON RIP FENCE

Wood facings (A) Fig. 53A are necessary on some special operations to one or both sides of the rip fence. The wood facing is attached to the fence with screws through the holes in the fence. Most work will require a 3/4" stock, although an occasional job may require 1" facing.

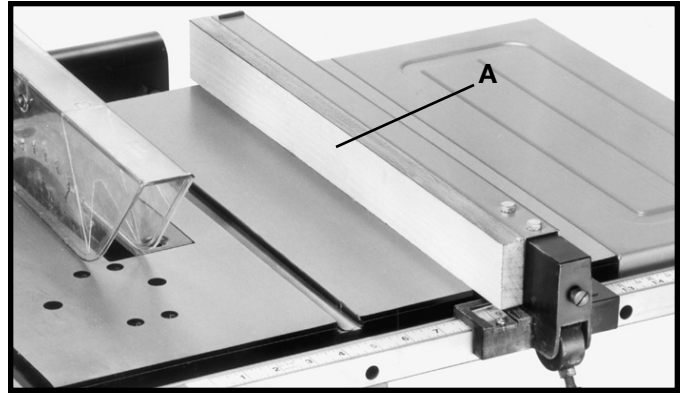

Fig. 53A

ACCESSORY DADO CUTTERHEAD

NOTE: THE MAXIMUM WIDTH DADO CUT FOR THIS SAW IS 1/2 INCH.

⚠ WARNING THE BLADE GUARD AND SPLITTER ASSEMBLY CANNOT BE USED WHEN DADOING. IT MUST BE REMOVED.

Before dadoing, loosen wing nut (A) Fig. 54 and take off the blade guard and splitter assembly (B). Keep assembly handy to replace it after dadoing.

1. Dadoing is cutting a rabbet or wide groove into the work. Most dado head sets are made up of two outside saws and four or five inside cutters, (Fig. 54A). Various combinations of saws and cutters are used to cut grooves from 1/8" to 13/16" for use in shelving, making joints, tenoning, grooving, etc. The cutters are heavily swaged and must be arranged so that this heavy portion falls in the gullets of the outside saws, as shown in Fig. 55. The saw and cutter overlap is shown in Fig. 56, (A) being the outside saw, (B) an inside cutter, and (C) a paper washer or washers, used as needed to control the exact width of groove. A 1/4" groove is cut by using the two outside saws. The teeth of the saws should be positioned so that the raker on one saw is beside the cutting teeth on the other saw.

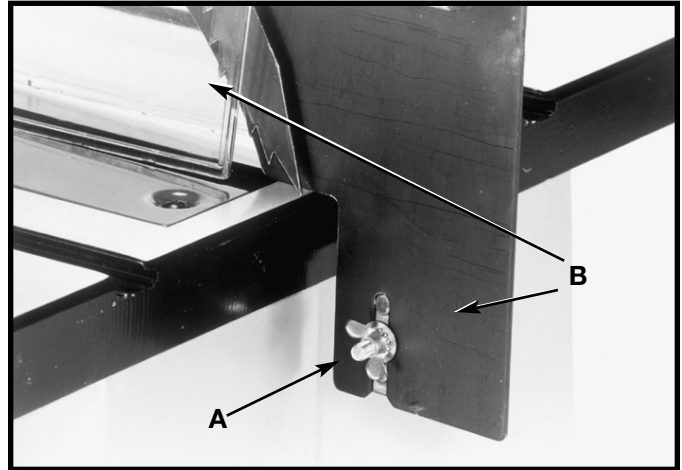

Fig. 54

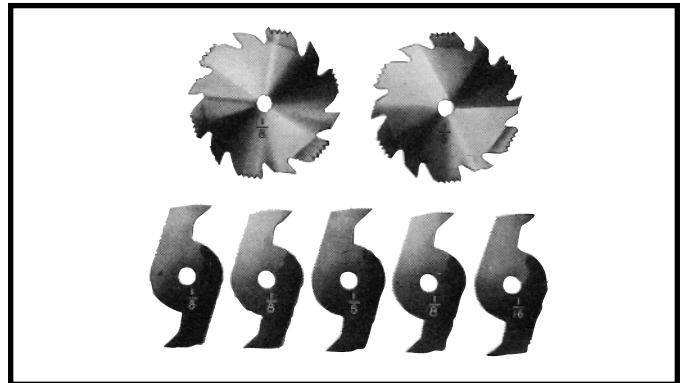

Fig. 54A

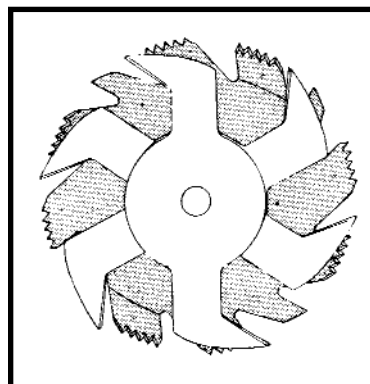

Fig. 55

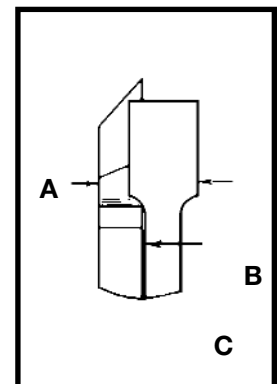

Fig. 56

2. Attach the dado head set (D) Fig. 57, to the saw arbor.

NOTE: THE OUTSIDE ARBOR FLANGE CAN NOT BE USED WITH THE DADO HEAD SET, TIGHTEN THE ARBOR NUT AGAINST THE DADO HEAD SET BODY. DO NOT LOSE THE OUTSIDE ARBOR FLANGE. IT WILL BE NEEDED WHEN REATTACHING A BLADE TO THE ARBOR.

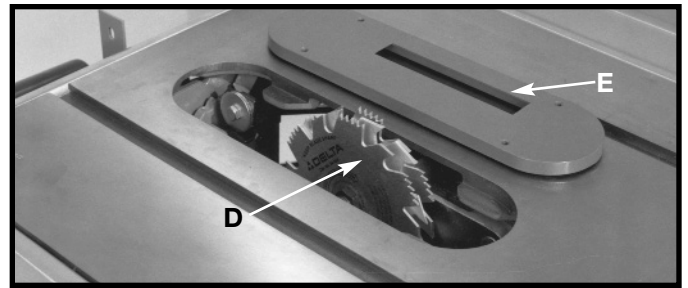

Fig. 57

⚠ CAUTION THE ACCESSORY DADO HEAD SET TABLE INSERT (E) FIG. 57, MUST BE USED IN PLACE OF THE STANDARD TABLE INSERT.

⚠ WARNING THE BLADE GUARD AND SPLITTER ASSEMBLY CANNOT BE USED WHEN DADOING AND MUST BE REMOVED OR SWUNG TO THE REAR OF THE SAW. AUXILIARY JIGS, FIXTURES, PUSH STICKS AND FEATHER BOARDS CAN AND SHOULD BE USED.

3. Fig. 58, shows a typical dado operation using the miter gage as a guide.

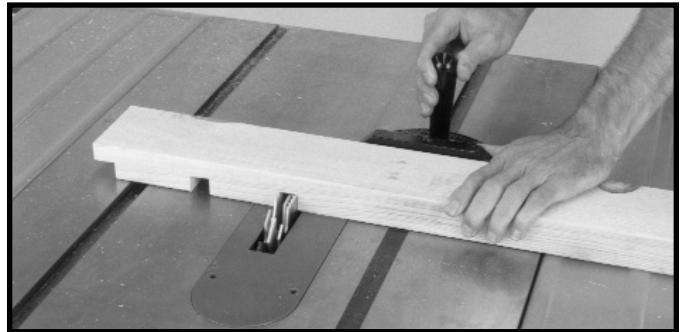

Fig. 58

⚠ CAUTION NEVER USE THE DADO HEAD IN A BEVEL POSITION.

⚠ WARNING ALWAYS INSTALL BLADE GUARD AFTER OPERATION IS COMPLETED.

CONSTRUCTING A FEATHERBOARD

Fig. 59, illustrates dimensions for making a typical featherboard. The material which the featherboard is constructed of, should be a straight piece of wood that is free of knots and cracks. Featherboards are used to keep the work in contact with the fence and table and help prevent kickbacks. Clamp the featherboards to the fence and table so that the leading edge of the featherboards will support the workpiece until the cut is completed. Use featherboards for all non "thru-sawing" operations where the guard and spreader assembly must be removed (see Fig. 60). Always replace the guard and spreader assembly when the non thru-sawing operation is completed.

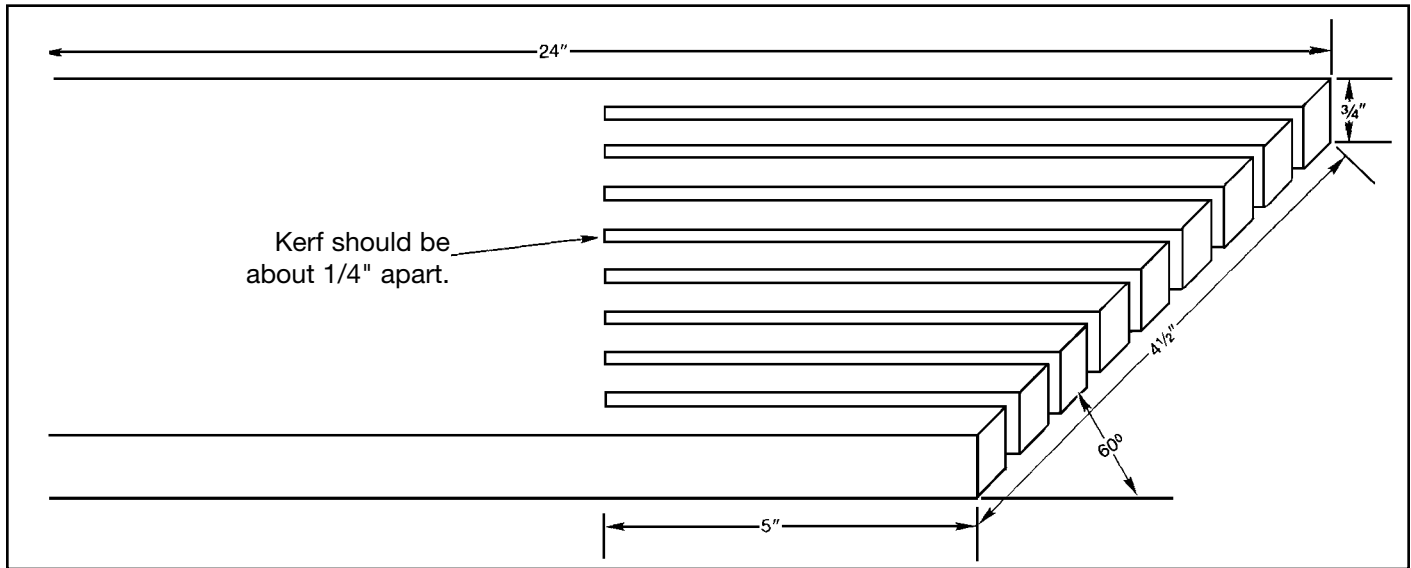

Fig. 59

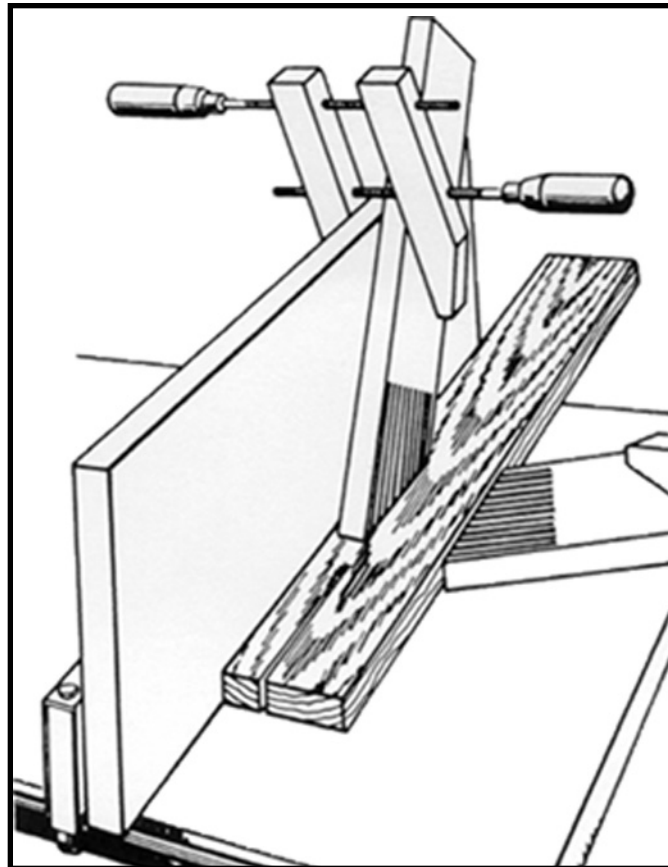

Fig. 60

CONSTRUCTING A PUSH STICK

When ripping work less than 4 inches wide, a push stick should be used to complete the feed and could easily be made from scrap material by following the pattern shown in Fig. 61.

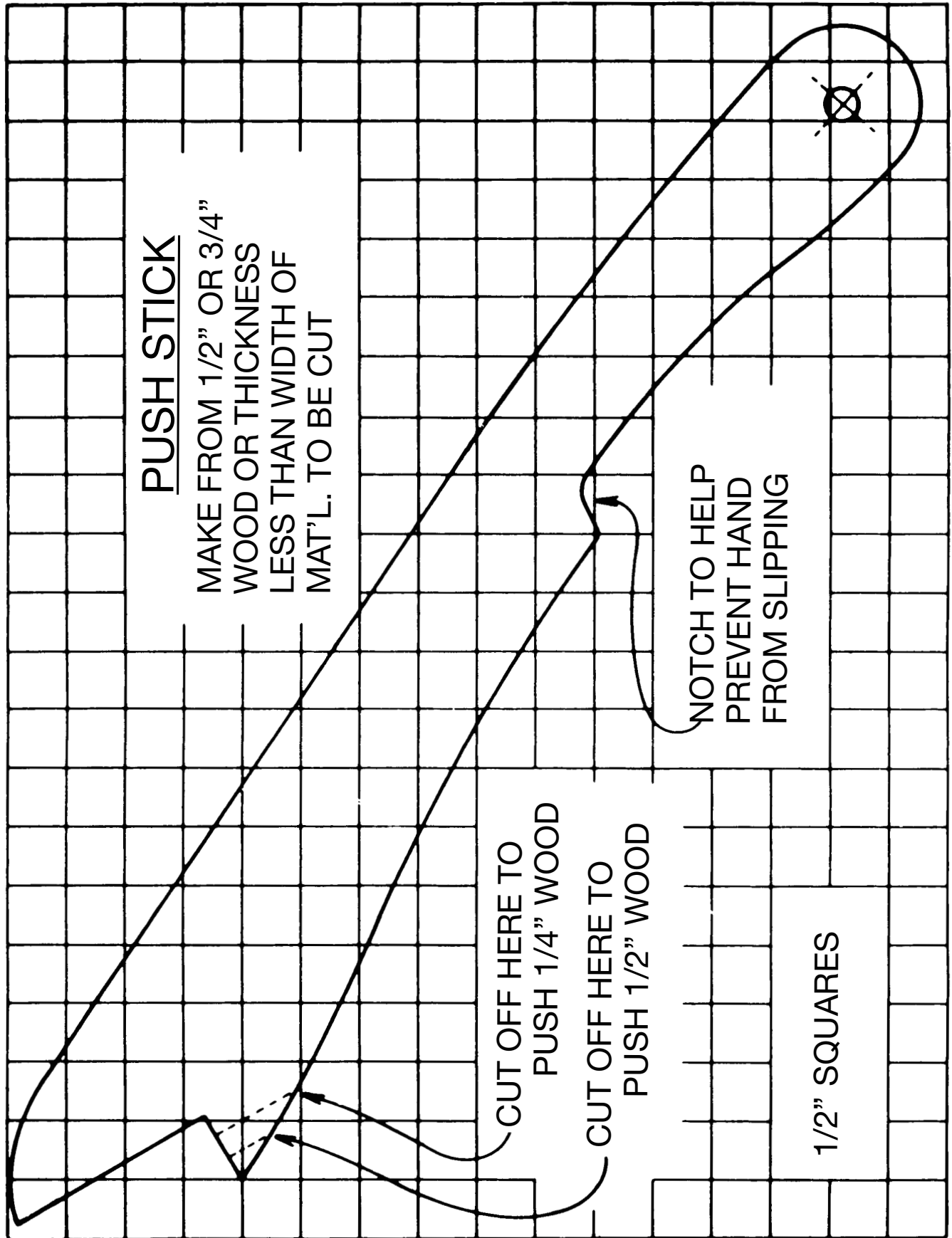

Fig. 61

ACCESSORIES

A complete line of accessories is available from your Delta Supplier, Porter-Cable • Delta Factory Service Centers, and Delta Authorized Service Stations. Please visit our Web Site www.deltamachinery.com for a catalog or for the name of your nearest supplier.

▲ WARNING Since accessories other than those offered by Delta have not been tested with this product, use of such accessories could be hazardous. For safest operation, only Delta recommended accessories should be used with this product.



PARTS, SERVICE OR WARRANTY ASSISTANCE

All Delta Machines and accessories are manufactured to high quality standards and are serviced by a network of Porter-Cable • Delta Factory Service Centers and Delta Authorized Service Stations. To obtain additional information regarding your Delta quality product or to obtain parts, service, warranty assistance, or the location of the nearest service outlet, please call 1-800-223-7278 (In Canada call 1-800-463-3582).



Two Year Limited New Product Warranty

Delta will repair or replace, at its expense and at its option, any new Delta machine, machine part, or machine accessory which in normal use has proven to be defective in workmanship or material, provided that the customer returns the product prepaid to a Delta factory service center or authorized service station with proof of purchase of the product within two years and provides Delta with reasonable opportunity to verify the alleged defect by inspection. For all refurbished Delta product, the warranty period is 180 days. Delta may require that electric motors be returned prepaid to a motor manufacturer's authorized station for inspection and repair or replacement. Delta will not be responsible for any asserted defect which has resulted from normal wear, misuse, abuse or repair or alteration made or specifically authorized by anyone other than an authorized Delta service facility or representative. Under no circumstances will Delta be liable for incidental or consequential damages resulting from defective products. This warranty is Delta's sole warranty and sets forth the customer's exclusive remedy, with respect to defective products; all other warranties, express or implied, whether of merchantability, fitness for purpose, or otherwise, are expressly disclaimed by Delta.

PORTER-CABLE • DELTA SERVICE CENTERS (CENTROS DE SERVICIO DE PORTER-CABLE • DELTA)

Parts and Repair Service for Porter-Cable • Delta Machinery are Available at These Locations
(Obtenga Refaccion de Partes o Servicio para su Herramienta en los Siguietes Centros de Porter-Cable • Delta)

ARIZONA

Tempe 85282 (Phoenix)
2400 West Southern Avenue
Suite 105
Phone: (602) 437-1200
Fax: (602) 437-2200

CALIFORNIA

Ontario 91761 (Los Angeles)
3949A East Guasti Road
Phone: (909) 390-5555
Fax: (909) 390-5554

San Diego 92111

7638 Clairemnot Blvd.
Phone: (858) 277-9595
Fax: (858) 277-9696

San Leandro 94577 (Oakland)
3039 Teagarden Street
Phone: (510) 357-9762
Fax: (510) 357-7939

COLORADO

Arvada 80003 (Denver)
8175 Sheridan Blvd., Unit S
Phone: (303) 487-1809
Fax: (303) 487-1868

FLORIDA

Davie 33314 (Miami)
4343 South State Rd. 7 (441)
Unit #107
Phone: (954) 321-6635
Fax: (954) 321-6638

Tampa 33609

4538 W. Kennedy Boulevard
Phone: (813) 877-9585
Fax: (813) 289-7948

GEORGIA

Forest Park 30297 (Atlanta)
5442 Frontage Road,
Suite 112
Phone: (404) 608-0006
Fax: (404) 608-1123

ILLINOIS

Addison 60101 (Chicago)
400 South Rohlwing Rd.
Phone: (630) 424-8805
Fax: (630) 424-8895

Woodridge 60517 (Chicago)
2033 West 75th Street
Phone: (630) 910-9200
Fax: (630) 910-0360

MARYLAND

Elkridge 21075 (Baltimore)
7397-102 Washington Blvd.
Phone: (410) 799-9394
Fax: (410) 799-9398

MASSACHUSETTS

Franklin 02038 (Boston)
Franklin Industrial Park
101E Constitution Blvd.
Phone: (508) 520-8802
Fax: (508) 528-8089

MICHIGAN

Madison Heights 48071 (Detroit)
30475 Stephenson Highway
Phone: (248) 597-5000
Fax: (248) 597-5004

MINNESOTA

Minneapolis 55429
5522 Lakeland Avenue North
Phone: (763) 561-9080
Fax: (763) 561-0653

MISSOURI

North Kansas City 64116
1141 Swift Avenue
Phone: (816) 221-2070
Fax: (816) 221-2897

St. Louis 63119

7574 Watson Road
Phone: (314) 968-8950
Fax: (314) 968-2790

NEW YORK

Flushing 11365-1595 (N.Y.C.)
175-25 Horace Harding Expwy.
Phone: (718) 225-2040
Fax: (718) 423-9619

NORTH CAROLINA

Charlotte 28270
9129 Monroe Road, Suite 115
Phone: (704) 841-1176
Fax: (704) 708-4625

OHIO

Columbus 43214
4560 Indianola Avenue
Phone: (614) 263-0929
Fax: (614) 263-1238

Cleveland 44125

8001 Sweet Valley Drive
Unit #19
Phone: (216) 447-9030
Fax: (216) 447-3097

OREGON

Portland 97230
4916 NE 122 nd Ave.
Phone: (503) 252-0107
Fax: (503) 252-2123

PENNSYLVANIA

Willow Grove 19090
(Philadelphia)
520 North York Road
Phone: (215) 658-1430
Fax: (215) 658-1433

TEXAS

Carrollton 75006 (Dallas)
1300 Interstate 35 N, Suite 112
Phone: (972) 446-2996
Fax: (972) 446-8157

Houston 77043

4321 Sam Houston Parkway,
West
Suite 180
Phone: (713) 983-9910
Fax: (713) 983-6645

WASHINGTON

Auburn 98001 (Seattle)
3320 West Valley HWY, North
Building D, Suite 111
Phone: (253) 333-8353
Fax: (253) 333-9613

Authorized Service Stations are located in many large cities. Telephone **800-438-2486** or **731-541-6042** for assistance locating one. Parts and accessories for Porter-Cable-Delta products should be obtained by contacting any Porter-Cable-Delta Distributor, Authorized Service Center, or Porter-Cable-Delta Factory Service Center. If you do not have access to any of these, call **800-223-7278** and you will be directed to the nearest Porter-Cable-Delta Factory Service Center. Las Estaciones de Servicio Autorizadas están ubicadas en muchas grandes ciudades. Llame al **800-438-2486** ó al **731-541-6042** para obtener asistencia a fin de localizar una. Las piezas y los accesorios para los productos Porter-Cable-Delta deben obtenerse poniéndose en contacto con cualquier distribuidor Porter-Cable-Delta, Centro de Servicio Autorizado o Centro de Servicio de Fábrica Porter-Cable-Delta. Si no tiene acceso a ninguna de estas opciones, llame al **800-223-7278** y le dirigirán al Centro de Servicio de Fábrica Porter-Cable-Delta más cercano.

CANADIAN PORTER-CABLE • DELTA SERVICE CENTERS

ALBERTA

Bay 6, 2520-23rd St. N.E.
Calgary, Alberta
T2E 8L2
Phone: (403) 735-6166
Fax: (403) 735-6144

BRITISH COLUMBIA

8520 Baxter Place
Burnaby, B.C.
V5A 4T8
Phone: (604) 420-0102
Fax: (604) 420-3522

MANITOBA

1699 Dublin Avenue
Winnipeg, Manitoba
R3H 0H2
Phone: (204) 633-9259
Fax: (204) 632-1976

ONTARIO

505 Southgate Drive
Guelph, Ontario
N1H 6M7
Phone: (519) 767-4132
Fax: (519) 767-4131

QUÉBEC

1515 ave.
St-Jean Baptiste, Suite 160
Québec, Québec
G2E 5E2
Phone: (418) 877-7112
Fax: (418) 877-7123

1447, Begin
St-Laurent, (Montréal),
Québec
H4R 1V8
Phone: (514) 336-8772
Fax: (514) 336-3505

The following are trademarks of PORTER-CABLE • DELTA (Las siguientes son marcas registradas de PORTER-CABLE • DELTA S.A.) (Les marques suivantes sont des marques de fabricant de la PORTER-CABLE • DELTA): Auto-Set®, BAMMER®, B.O.S.S.®, Builder's Saw®, Contractor's Saw®, Contractor's Saw II™, Delta®, DELTACRAFT®, DELTAGRAM™, Delta Series 2000™, DURATRAC™, Emc²™, FLEX®, Flying Chips™, FRAME SAW®, Grip Vac™, Homecraft®, INNOVATION THAT WORKS®, Jet-Lock®, JETSTREAM®, 'kickstand', LASERLOC®, MICRO-SET®, Micro-Set®, MIDI LATHE®, MORTEN™, NETWORK™, OMNIJIG®, POCKET CUTTER®, PORTA-BAND®, PORTA-PLANE®, PORTER-CABLE®&(design), PORTER-CABLE®PROFESSIONAL POWER TOOLS, PORTER-CABLE REDEFINING PERFORMANCE™, Posi-Matic®, Q-3®&(design), QUICKSAND®&(design), QUICKSET™, QUICKSET II®, QUICKSET PLUS™, RIPTIDE™&(design), SAFE GUARD II®, SAFE-LOC®, Sanding Center®, SANDTRAP®&(design), SAW BOSS®, Sawbuck™, Sidekick®, SPEED-BLOC®, SPEEDMATIC®, SPEEDTRONIC®, STAIR EASE®, The American Woodshop®&(design), The Lumber Company®&(design), THE PROFESSIONAL EDGE®, THE PROFESSIONAL SELECT®, THIN-LINE™, TIGER®, TIGER CUB®, TIGER SAW®, TORQBUSTER®, TORQ-BUSTER®, TRU-MATCH™, TWIN-LITE®, UNIGUARD®, Unifence®, UNIFEEDER™, Unihead®, Uniplane™, Unirip®, Unisaw®, Univise®, Versa-Feeder®, VERSA-PLANE®, WHISPER SERIES®, WOODWORKER'S CHOICE™.

Trademarks noted with ™ and ® are registered in the United States Patent and Trademark Office and may also be registered in other countries. Las Marcas Registradas con el signo de ™ y ® son registradas por la Oficina de Registros y Patentes de los Estados Unidos y también pueden estar registradas en otros países. Printed in U.S.A. PC-0104-149